



# Specifications, Installation, Operation Service and Spare Parts Manual **PH-Series PATIO HEATER**



Gas Fired Outdoor Infrared Patio Heater/*Gas-Fired Infrared Patio Heater*  
Vented Radiant Tube Heater/ *L'Appareil de chauffage de Tube Rayonnant donné vent*  
Gravity Vented Wall Furnace/ *La gravité A Donné vent Fournaise de Mur*

MODELS PH40, 50 & 75 ONLY: For either indoor or outdoor installation/Installer à l'intérieur ou à l'extérieur  
For Industrial, Commercial, and Residential Patio and Restaurant Applications.

**⚠ WARNING: MODELS PH-40HO & PH-75HO  
For Outdoor Use Only**

**⚠ WARNING:** Improper installation, adjustment, alteration, service or maintenance can cause property damage, injury or death. Read (refer to) the installation operating and maintenance instructions thoroughly before installing or servicing this equipment. For assistance or additional information consult a qualified installer, service agency or the gas supplier.

**⚠ WARNING:** If the information in these instructions are not followed exactly, a fire or explosion may result causing property damage, personal injury or loss of life.

-Do not store or use gasoline or other flammable vapors and liquids in the vicinity of this or any other appliance.

**⚠ DANGER: WHAT TO DO IF YOU SMELL GAS:**

- 1) Extinguish any open flame
- 2) DO NOT try to light any appliance.
- 3) DO NOT use or touch any electrical switches.
- 4) DO NOT use any phone in your building
- 5) Turn off gas.
- 6) Open Windows
- 7) Leave the building
- 8) Immediately call your gas supplier from a neighbour's phone or after you have left the building. Follow the gas supplier's instructions.
- 9) If you cannot reach your gas supplier, call the fire department.

- Installation and service must be performed by a qualified installer, service agency or the gas supplier

**⚠ ADVERTISSEMENT.** L'installation déplacée, l'ajustement, le changement, le service ou l'entretien peuvent causer les dommages de propriété, la blessure ou la mort. Lire (se référer à) l'installation qui fonctionne et les instructions d'entretien à fond avant d'installer ou entretenir cet équipement. Pour obtenir de l'aide ou les informations supplémentaires consultez un programme d'installation, une agence de service ou le fournisseur de gaz qualifié.

**⚠ ADVERTISSEMENT:** Assurez-vous de bien suivre les instructions données dans cette notice pour réduire au minimum le risqué d'incendie ou d'explosion ou pour éviter tout dommage matériel, toute blessure ou la mort.

- Ne pas entreposer ni utiliser d'essence ni d'autres vapours ou liquids inflammables a proximité de cet appateil ou de tout autre appareil.

**⚠ DANGER: QUE FAIRE SI VOUV SENTEZ UNE ODEUR DE GAZ:**

- 1) Eteindre la flamme ouverte
- 2) Ne pas tenter d'allumer d'appareils
- 3) Ne touchez á aucun interrupteur.
- 4) Ne pas vous server des telephones dans le bâtiment où vous vous trouvez.
- 5) le Virage du gaz.
- 6) Ouvrir Windows
- 7) Part le bâtiment
- 8) Appelez immédiatement votre fournisseur de gaz depuis un voisin ou après que vous êtes parti le bâtiment. Suivez les instructions du fournisseur.
- 9) Si vous ne pouvez rejoindre le service des incendies.

- L'installation et l'entretien doivent être assures par un installateur ou un service d'entretien qualifié ou par fournisseur de gaz.

**⚠ WARNING:** Heat exchanger surface is hot. Do not touch surface or burn may result. Combustible material or articles should not be placed on or near heater. Observe clearance to combustibles as noted on heater and in this manual.

**INSTALLER:** Leave this manual with the appliance.

**CONSUMER:** Retain this manual for future reference.

**INSATLLATEUR:** Laissez cette notice avec l'appareil.

**CONSOMMATEUR:** Conservez cette notice our consultation ultérieure.

Calcana USA Ltd.  
30245 Suite A,  
County Rd 49, Loxley, AL, 36551  
Tel: 251-964-4400  
Fax: 251-964-4404

## TABLE OF CONTENTS

Owners Responsibility 1		Parts:	
Installers Responsibility.....	3	- Burner Head Parts.....	35
Code Compliance.....	4	- Reflector and Tube Parts.....	36
Specifications.....	5-	- Parts List.....	37
Dimensions.....	6 & 6A	Warranty.....	38
Clearance to Combustibles .....	7	Fuel Conversion.....	39
Pre-installation Inspection .....	8	Lighting & Operating Instructions...42	
Installation:			
- Planning.....	9		
- Assembly of Components.....	10		
- Suspension Details .....	11		
- 25°Tilt Installation.....	11		
- Assembly PH – 50 & 75.....	12		
- Joint Hanger to Reflector.....	13		
- Clamp Coupler .....	13		
- Reflector Strap .....	14		
- End Cap to Reflector.....	14		
- 90° Elbow Kit .....	15		
- 180° U-Bend Kit .....	15		
- Ventilation Requirements.....	15A		
-Venting (PH-40, 50 & 75 only).....	15B, C, D,E		
Gas Piping .....	16		
Gas Connection.....	18 & 19		
Electrical Connection 120 Volt.....	20		
Wiring Diagram 120 Volt.....	21		
Electrical Connection 24 Volt.....	22		
Wiring Diagram 24 Volt.....	23		
Initial Start-Up .....	24		
Gas Valve Details .....	25		
Checking Gas Input Rate.....	26		
Sequence of Opertaion.....	28		
Troubleshooting			
- No Power To Heater .....	29		
- Initial Electrical Check.....	30		
- Initial Gas Checks .....	30		
- Electricity & Gas to Heater but Still Inoperative.....	30		
- Check Control Board.....	31		
- Fault Conditions .....	31		
- Internal Control Fault .....	31		
- Air Flow Fault.....	31		
- Flame with No Call For Heat.....	32		
- Ignition Lock Out .....	32		
- Flame Sensor Current Check .....	32		
- Proper Electrode Location .....	33		
Maintenance .....	34		

## TABLE OF FIGURES

Figure #	Description	Page #
1	Equipment Dimensions Side View.....	6
1A	Patio Heater End Profiles.....	6A
2	Clearance to Combustibles Horizontal Installation.....	7
3	Clearance to Combustibles 25° Tilt.....	7
4	Clearance to Combustibles End Clearance.....	7
5	Suspension Details.....	11
	- Chain Mounting	
6	Suspension Details - Rigid Mounting .....	11
7	Assembly-PH50 & 75.....	12
8	Joint Hanger Installation.....	13
9	Tube Clamp Installation.....	13
10	Reflector Support Strap Installation .....	14
11	End Cap Installation .....	14
12	90° Elbow Kit Installation.....	15
13	180° U-Bend Kit Installation .....	15
14	Hard Pipe Installation .....	18
15	Gas Line Connection with Certified Flexible Connector .....	19
16	Electrical Connections 120 Volt.....	20
17	Wiring Diagram 120 Volt .....	21
18	Electrical Connection 24 Volt.....	22
19	Wiring Diagram 24 Volt.....	23
20	Gas Valve.....	25
21	Flame Sensor Current Check.....	32
22	Proper Electrode Location.....	33
23	Burner Head Parts.....	35
24	Reflector and Tube Parts.....	36

Thank you for purchasing our product. We have designed this unit to provide you with years of trouble free heating enjoyment.

**READ THIS MANUAL IN ITS ENTIRETY!** If you do not understand any of the safety or hazardous warnings contained in this manual, or have questions or concerns about the installation, operation, maintenance or service of this heater, or any other questions or concerns relating to this heater, you **MUST CALL THE FACTORY** at the telephone number noted on the front cover of this manual or as detailed on the rating plate on the heater before operating this heater. Store this manual in a location near the heater, for future reference. Make sure installation is performed by well-qualified, licensed contractors in the required field of work. If in doubt, DO NOT allow unit to be installed. DO NOT park vehicles or place combustible objects close to the heater other than specified on the Clearance to Combustible chart located in this manual and on the heater. Failure to observe the clearance to combustibles can result in property damage, injury or death.

**IMPORTANT NOTICE:** The installation portion of these instructions are for the use of qualified individuals specially trained, licensed and experienced in the installation of this type of equipment and related system components.

**NOTE:** - The words "shall" or "must", indicate a requirement, which is essential to satisfactory and safe performance.

**⚠ GENERAL HAZARD WARNING:** The heater and related gas piping, fitting & wiring must be installed by individuals or firms qualified, licensed and specially trained and experienced in installation of this type of equipment and related system components. Only persons who can understand and follow the instructions shall install or service this heater. Persons not qualified shall not install this equipment nor interpret these instructions. Failure to comply with the precautions and instructions provided with this heater can result in death, serious bodily injury and property loss or damage from hazards of fire, explosion, burn, asphyxiation, carbon monoxide poisoning or electrical shock.

**⚠ WARNING:** Installation and repair should be done by a qualified service person. The heater should be inspected before use and at least annually by a qualified service person and prior to heating season. Heaters used in dusty locations such as brooder barns, sawmills, woodworking shops, etc. will require more maintenance on a more regular basis and more frequent cleaning may be required as necessary. It is imperative that the control compartments, burner(s) and circulating air passageways of the appliance be kept clean. Periodic examination of the venting system is to be performed. No one should work on a heater unless they are a licensed/qualified gas fitter or contractor. For all repairs, parts **MUST** originate from the manufacturer of this heater in order not to void CGA/AGA certification. Safety devices are not allowed to be rendered inoperative and left unattended as this action can cause property damage, injury or death. Failure to do so will void your warranty.

**WARNING:**

Improper installation, adjustment, alteration, servicing or maintenance can cause property damage, injury or death.

**WARNING:**

Children and adults should be alerted to the hazards of high surface temperatures and should stay away to avoid burns or clothing ignition.

Young children should be carefully supervised when they are in the same place as the heater.

Clothing or other flammable materials should not be hung from the heater, or places on or near the heater.

Any guard or other protective device removed for servicing a heater must be replaced prior to operating the heater.

**WARNING:**

MODELS PH-40HO and PH-75HO ONLY: These appliance shall be used only outdoors in a well-ventilated space and shall not be used in a building, garage or any other enclosed area.

**WARNING****California Proposition 65**

If not installed, operated and maintained in accordance with manufacturer's instructions. This product could expose you to substances in the fuel or from combustion which can cause death or series illness and which are known to the State of California to cause cancer, birth defects or reproductive harm.

Do not use this appliance if any part has been under water. Immediately call a qualified service technician to inspect the appliance and to replace any part of the control system and any gas control which has been under water.

Ne pas se servir de cet appareil s'il a été plonge dans l'eau, complètement ou en partie. Faire inspecter l'appareil par un technicien qualifié et remplacer toute partie du système de control et toute commande qui ont été plongée dans l'eau.

**⚠ WARNING: SEE PAGE 15A FOR VENTILATION REQUIREMENTS FOR THIS HEATER. MAKE SURE YOU HAVE THE CORRECT MODEL FOR THE INTENDED APPLICATION. IF IN DOUBT CONTACT THE FACTORY FOR DETAILS PRIOR TO INSTALLATION OR OPERATION.**

**WARNING:****FIRE OR EXPLOSION HAZARD**

The heater and related gas piping and wiring must be installed only by individuals or firms well qualified and licensed in the required field of work.

Read and understand this manual in its entirety BEFORE you install this heater. If you have any questions call your local representative. Verify that the fuel on the installation site is the same as what is required for this heater. Check heater for damage or missing parts. If damage has occurred, notify carrier or point of purchase at once for reconciliation of damaged goods. We are not responsible for transit damage. Do not install if heater is damaged.

**If you do not understand any of the safety or hazardous warnings contained in this manual, or have questions or concerns about the installation, operation, maintenance or service of this heater, or any other questions or concerns relating to this heater, you MUST CALL THE MANUFACTURER at the telephone number noted on the front cover of this manual or as detailed on the rating plate on the heater before operating this heater.**

Verify that model, input & length is what was ordered and is appropriate for installation. This appliance shall be use only outdoors in a well ventilated space and shall not be used in a building, garage, or any other enclosed area.

Installation shall be in accordance with local codes. (see code compliance).

If installation requires tilting, DO NOT over tilt the unit. Units are certified for installations up to 25°.

Install unit according to the Clearance to Combustibles for that particular heater and type of installation. Make sure that clearances are maintained from vehicles parked or combustibles below or in front of heater. Failure to do so could result in property damage, injury or death.

Make sure unit is adequately suspended from ceiling or roof. Select hanging location that has adequate strength to support heater.

Adequate clearance around air openings into the combustion chamber, clearance from combustible material, provisions for accessibility and for combustion and ventilation air supply.

Do not render safety devices inoperable. Make sure gas line and/or service have adequate capacity for the increased load of heater.

Check line and manifold pressure with a manometer to confirm unit is set according to the specification on the rating plate and altitude. Perform check with all gas-fired appliances operating. (see pages 24, 25, 26 & 27 for further details).

Provide adequate accessibility clearances for servicing.

Leave copy of this manual with owner (or a copy) for future reference.

This heater needs fresh air for safe operation and must be installed so there are provisions for adequate combustion and ventilation air. If in a confined space make sure model of heater can be installed and attached to either a sidewall or roof vent. Models PH-40, 50 & 75 can be installed in this fashion.

The PH-40, 50 & 75 heaters must not be connected to a chimney flue serving a separate solid-fuel burning appliance. These models, in a space heating application, must only be installed with the venting that they are certified for. Refer to the installation instructions for installation details. If you are installing a PH-40, 50 or 75 unit indoors it will need to be vented either with a sidewall vent kit, (use pin #800208 sidewall vent kit) or via a certified "B" vent system through the roof. For side wall applications, make sure vent cap is past eave. (see pages titled 'Venting'). **PH-40HO & PH-75HO units are for outdoor applications only.**

Continued on page 4



## WARNING

### FIRE OR EXPLOSION HAZARD

Make sure units are operating as quiet and efficient as possible before leaving the job site and instruct owner/s on the safe operation of the heater as well as safety and hazardous issues as they relate to the heater, its installation, operation and this manual.

Leave this manual with the consumer and instruct them to retain the manual for future reference.



## WARNING

### California Proposition 65

If not installed, operated and maintained in accordance with manufacturer's instructions. This product could expose you to substances in the fuel or from combustion which can cause death or serious illness and which are known to the State of California to cause cancer, birth defects or reproductive harm.

**HEATER OPERATION NOTE:** PH-40, 50 & 75 Patio Heaters will have a higher heat output at the burner end as compared to the exhaust end.

**SPACE HEATING:** As a general rule, it is suggested to locate the burner end toward the highest heat-loss area (doors) of the space being heated. If you have any concerns or questions concerning orientation or layout of the heater in your application, contact factory for assistance.

**SPOT or OUTDOOR HEATING:** On PH-40, 50 & 75 heaters with a straight line configuration, there will be a noticeable and more pronounced perception of greater heat output from the burner end of the heater as compared to the exhaust end. **As a general rule, it is suggested for spot heating applications, to use the PH-40HO or PH-75HO models or a u-tube configuration to provide a more even source of heat; or two units, side by side with the burner heads at opposite ends to promote even heating.** If you have any concerns or questions concerning orientation or layout of the heater in your application, contact factory for assistance.

**NOTE:** A small amount of condensation may occur from the heater when it starts the heating cycle. The condensation will stop once the heater warms up. On models PH-40, 50 & 75, and if using a venting system, make sure venting is sealed according section titled "Venting".

### CODE COMPLIANCE

Installation shall be in accordance with local building codes, or in the absence of local codes, in accordance with:

**A) FUEL SUPPLY:**

CANADA: *Natural Gas and Propane Installation Code, CSA B149.1* or latest edition.

USA: *National Fuel Gas Code, ANSI Z223.1/NFPA 54*, or latest edition.

**B) ELECTRICAL GROUNDING:**

CANADA: *Canadian Electrical Code, CSA C22.1* or latest edition.

USA: *National Electrical Code, ANSI/NFPA 70* or latest edition

In Canada: Electrical equipment and wiring shall comply with the applicable provisions of the current *Canadian Electrical Code, CAN/CSA C22.1, Part I and Part II, and CAN/CSA C22.2 No. 3, Electrical features of Fuel Burning Equipment.*

**⚠ WARNING: SEE PAGE 15A FOR VENTILATION REQUIREMENTS FOR THIS HEATER. MAKE SURE YOU HAVE THE CORRECT MODEL FOR THE INTENDED APPLICATION. IF IN DOUBT CONTACT THE FACTORY FOR DETAILS PRIOR TO INSTALLATION OR OPERATION.**

**Rating (Input: Natural and L.P. Gas)**

In Canada: 0 – 4500 ft (1372 m) In USA: 2 – 2000' (610m) –De-Rate Above 2000 (See Page 26)

Model	Burner Input		Length
	Min.	Max.	
PH - 40	20,000	40,000	137" (341 cm)
PH – 40 HO	20,000	50,000	64" (163 cm)
PH – 50	25,000	50,000	197" (501 cm)
PH - 75	37,500	75,000	257" (653)
PH – 75 HO	37,500	75,000	124" (315 cm)

**Gas Pressure at Manifold:**

Natural Gas.....Lo: 1.5 " (3.8 cm)      HI: 3.5" (8.89 cm) W.C.  
L.P. Gas.....Lo: 5.5" (13.97 cm)      Hi: 10.5" (26.67 cm) W.C.  
Gas Connection Size.....0.5" (1.27 cm) N.P.T.

**Gas Inlet Pressure:**

<i>GAS</i>	<i>MINIMUM</i>	<i>MAXIMUM</i>
Natural	4.5" (11.43 cm) W.C.	14.0" (35.56 cm) W.C.
L.P.	11.5" (29.21 cm) W.C.	14.0" (35.56 cm) W.C.

FOR MODELS PH-40, 50, & 75 ONLY: Vent Connection is 3" (7.62 cm)

**Electrical Rating:**

DSI Ignition  
120v. 60hz, 1 Amps  
24 volt low voltage control

**Standard Equipment:**

Burner control housing is preassembled and prewired, unit comes complete with the following: industry standard gas and electrical connections, balanced air rotor, thermal overload protected motor, visual burner inspection sight glass, combustion and air proving safety switches, 3-try spark ignition control, low voltage control connection, aluminized heat-treated steel combustion tube, polished aluminum standard reflector, aluminized steel radiant heat exchanger, tube couplers, joint/hanger pieces, heat economizer baffle, wave concentrator, grille, variable input control and remote control panel.

**Optional Equipment:**

- 90° Elbow Kit (PH-50, 75 Only)
- 180° U-Bend Kit (PH-50, 75 Only)
- Stainless Steel Construction
- 24 Volt Input
- Hanging Brackets



# PATIO HEATER SIDE DIMENSIONS

FIGURE #1

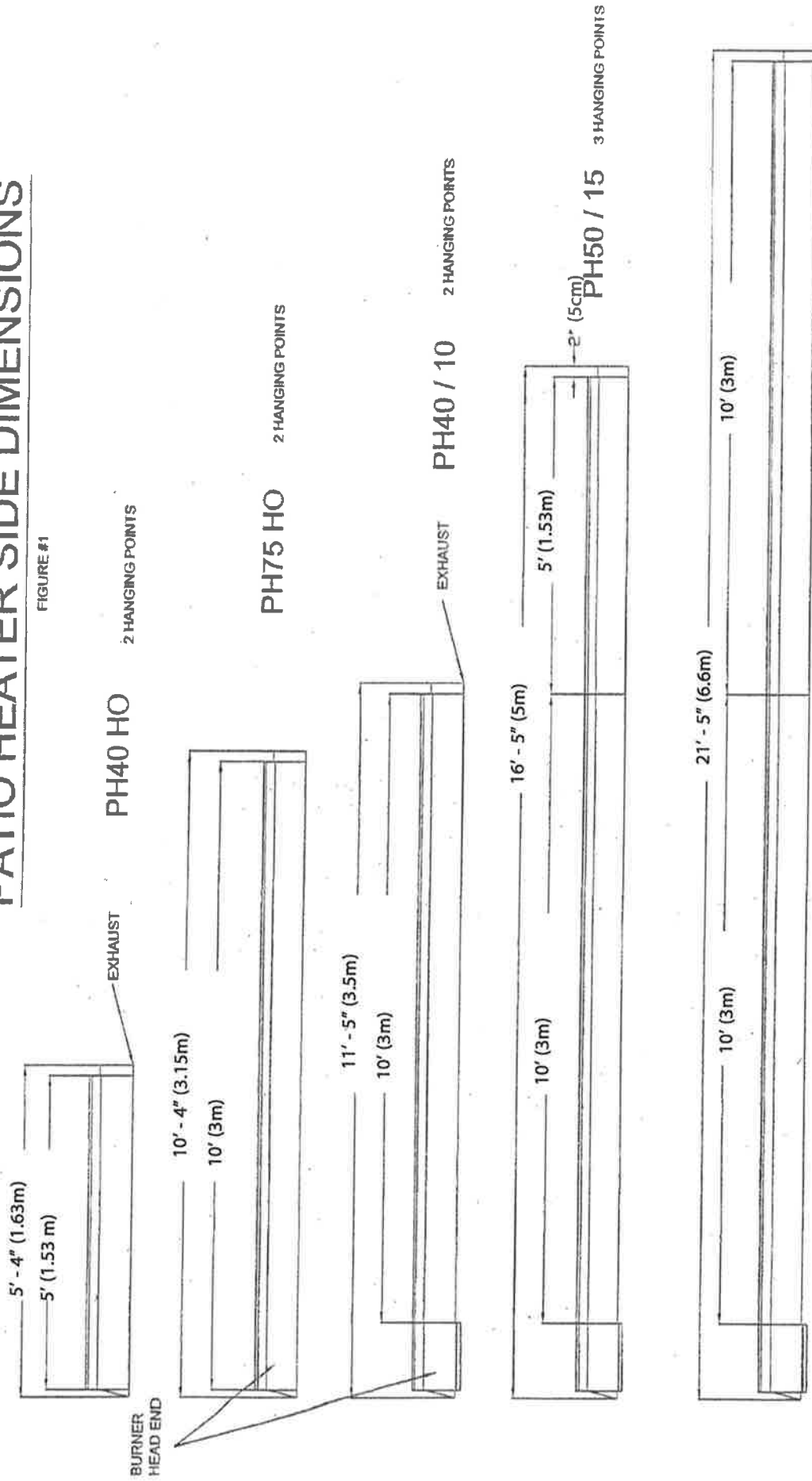

# PATIO HEATER END PROFILES

FIGURE #1A

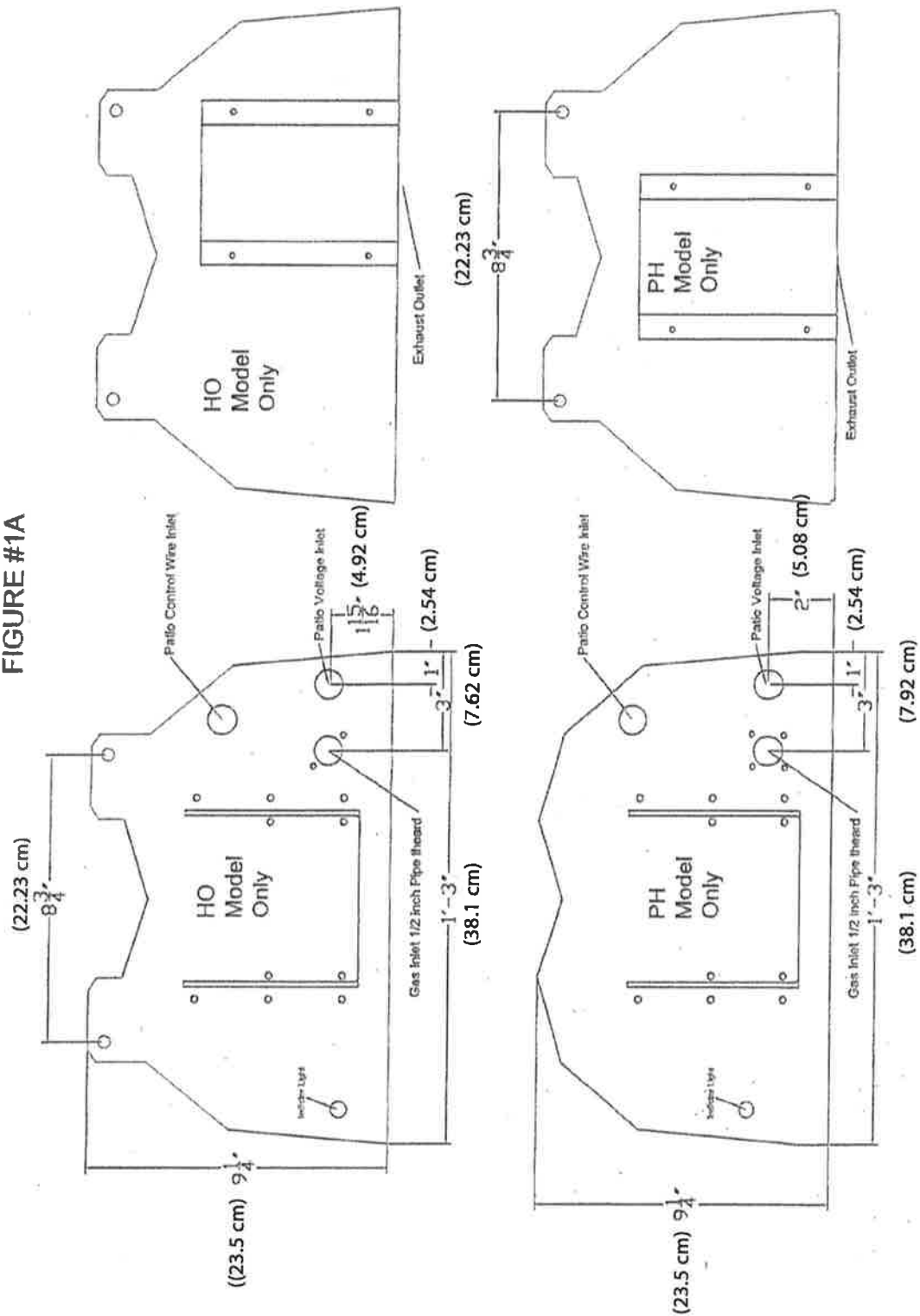

## INSTALLATION CLEARANCES AND CLEARANCE TO COMBUSTIBLES

Installation of overhead heaters in garages or hangars MUST meet the requirements for bottom (below) clearances detailed in CANADA: *Natural Gas and Propane Installation Code, CSA B149.1* or latest edition or USA: *National Fuel Gas Code, ANSI Z223.1/NFPA 54*, or latest edition.

Minimum mounting height from ground or floor to bottom portion of tube is 78" (199 cm)

**⚠ WARNING:** In all situations, clearance to combustibles must be maintained. Minimum clearance from heater must be maintained from vehicles parked below heater. The posting of signs may be required in storage areas referring to clearance to combustibles to the heater and/or limiting the stacking height of stored items near the heater specifying a maximum height. Clearances are not for use in four (4) sided enclosures. Certain materials or items, when stored under the heater, will be subjected to radiant heat and could be seriously damaged.

For Models PH-40, 50 & 75, when used indoors and vented accordingly, the stated clearance to combustibles represents a surface temperature of 90°F (32°C) above room temperature. Building material with low heat tolerance (such as plastics, vinyl siding, canvas, tri-ply, etc) may be subject to degradation at lower temperatures. It is the installer's responsibility to assure that adjacent materials are protected from degradation.

### END CLEARANCES (Burner Head End)

Minimum clearances from air intake end of burner head to object is 5" (12.7 cm).

Provide adequate accessibility clearances for servicing and proper operation.

Do not install unit in such a manner that the combustion air entering the heater is reduced in any manner.

(EXHAUST END)  
ALL MODELS  
OUTDOOR APPLICATIONS ONLY

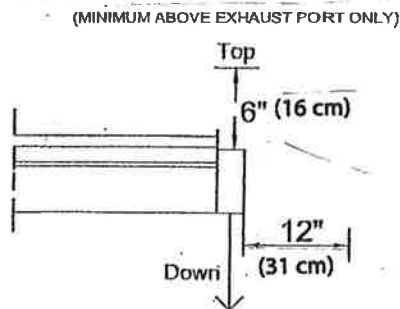
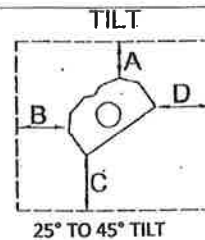
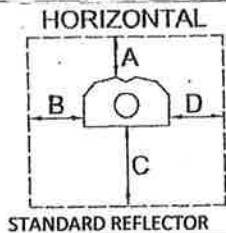
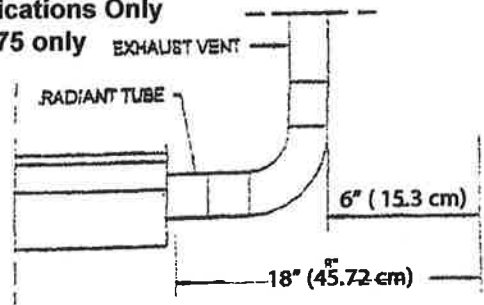

FIGURE #4  
END CLEARANCE

EXHAUST END:  
Vented Applications Only  
PH-40, 50 & 75 only



INSTALLATION TYPE 1				
INPUT	A	B	C	D
40	4" (10.2 cm)	12" (31 cm)	34" (87 cm)	12" (31 cm)
50	4" (10.2 cm)	12" (31 cm)	41" (105 cm)	12" (31 cm)
75	4" (10.2 cm)	15" (32 cm)	46" (117 cm)	15" (32 cm)
40HO	8" (21 cm)	17" (44 cm)	41" (105 cm)	17" (44 cm)
75HO	6" (15.3cm)	12" (31 cm)	42" (107 cm)	12" (31 cm)

INSTALLATION TYPE 1				
INPUT	A	B	C	D
40	4" (10.2 cm)	4" (10.2 cm)	31" (79 cm)	28" (72 cm)
50	4" (10.2 cm)	4" (10.2 cm)	35" (89 cm)	28" (72 cm)
75	4" (10.2 cm)	4" (10.2 cm)	40" (102 cm)	31" (79 cm)
40HO	8" (21 cm)	4" (10.2 cm)	28" (72 cm)	25" (64 cm)
75HO	6" (15.3cm)	4" (10.2 cm)	31" (79 cm)	22" (56 cm)

## **PRE-INSTALLATION INSPECTION:**

Inspect the shipping container and heater for any evidence of shipping damage. If heater damage is found, notify freight carrier and file a claim.



## **WARNING**

If heater is damaged, DO NOT install.

Check that all parts and pieces are present and accounted for. Report any missing items to carrier or point of purchase at once.

Check that overall general appearance, source of fuel required and model numbers match unit requested. Report any discrepancy to carrier or point of purchase at once.

### **THOROUGHLY INSPECT THE EQUIPMENT IMMEDIATELY UPON ARRIVAL**

OUR RESPONSIBILITY FOR THIS SHIPMENT CEASED WHEN THE CARRIER SIGNED THE WAYBILL.

If goods are received short or in damage condition, it is important that you notify the carrier and insist on a notation of the loss or damage across the face of the freight bill, otherwise no claim can be enforced against the transportation company.

If concealed loss or damage is discovered, notify your carrier at once and request an inspection. This is absolutely necessary. A concealed damage report must be made within 15-days of delivery of shipment. Unless you do this the carrier will not entertain any claim for loss or damage. The Agent will make an inspection and grant a concealed damage notation. If you give the Transportation Company a clear receipt for goods that have been damaged or lost in transit, you do so at your own risk and expense.

WE ARE WILLING TO ASSIST YOU IN EVERY POSSIBLE MANNER TO COLLECT CLAIMS FOR LOSS OR DAMAGE, BUT THIS WILLINGNESS ON OUR PART DOES NOT MAKE US RESPONSIBLE FOR COLLECTION OF CLAIMS OR REPLACEMENT OF MATERIAL. THE ACTUAL FILING AND PROCESSING OF THE CLAIM IS YOUR RESPONSIBILITY.

**WE ARE NOT RESPONSIBLE FOR FREIGHT DAMAGED IN TRANSIT!**

**IF CONTENTS ARE DAMAGED,  
EVEN THOUGH CARTON DOES NOT LOOK DAMAGED:**

- A. MAKE CLAIM TO DELIVERY CARRIER AT ONCE**
- B. SAVE CARTONS FOR INSPECTION BY CARRIER**

## **INSTALLATION:**

Provide for adequate clearance around air openings into the combustion chamber, clearances from combustible material, provisions for accessibility and for combustion and ventilating air supply.

### **PLANNING:**

- Familiarize yourself with the equipment and any accessories that you may require.
- Locate the area where unit is to be installed
- Locate area where any holes might have to be cut for:
  - a) Electrical and control wire.
  - b) Any gas piping requirements
  - c) Venting (PH-40, 50 or 75 only)
- Make sure that there is no obstruction such as hidden electrical wiring, water lines etc... in the areas of concern.
- Locate the control (All Models) and thermostat (PH-40, 50 or 75 models indoors only) location.



## **WARNING**

Observe minimum clearance to combustibles. REFER TO PAGE 7.

### **FOR 120 VOLT SYSTEM INSTALLATION**

- Locate a grounded, adequate electrical source.
- Measure required amount of various materials required to do the installation, and have these materials on site in an organized manner prior to commencement.

### **WARNING NOTES FOR INSTALLATION AND SUSPENSION OF THE OVERHEAD HEATER**

**⚠ WARNING:** If the installer is to install the heater via hanging chains, it is the responsibility of the installer to use hanging chain that has a minimum support capacity of no less than 100 lbs. Also make sure all suspension points are adequate to support weight of heater and any accessories. Also make sure all S-Hooks are affixed properly and the open ends squeezed closed. If the suspension system fails, it is the responsibility of the installer.

If utilizing installation brackets or another means of suspension is used, make sure all brackets and fasteners have sufficient load bearing capacity to satisfy the local codes as well as the extra load that may be placed upon the heater and suspension methods encountered during windy conditions.

**A FAILED SUSPENSION SYSTEM CAN CAUSE PROPERTY DAMAGE, SEVERE INJURY AND/OR DEATH. THE INSTALLER TAKES FULL RESPONSIBILITY AND LIABILITY FOR THE CORRECT AND ADEQUATE METHOD OF INSTALLATION AND SUSPENSION OF THE HEATER FOR THE CONDITIONS AND/OR LOCATION THAT IT IS TO BE INSTALLED AT. THE SUSPENSION DETAILS IN THIS MANUAL ARE SUGGESTIONS ONLY. IF IN DOUBT AS TO THE CORRECT METHODS TO INSTALL THIS HEATER FOR YOUR LOCAL CODES AND CONDITIONS, DO NOT INSTALL THE HEATER. CONTACT LOCAL BUILDING OFFICIALS FOR FURTHER INFORMATION.**

**⚠ WARNING: SEE PAGE 15A FOR VENTILATION REQUIREMENTS FOR THIS HEATER. MAKE SURE YOU HAVE THE CORRECT MODEL FOR THE INTENDED APPLICATION. IF IN DOUBT CONTACT THE FACTORY FOR DETAILS PRIOR TO INSTALLATION OR OPERATION.**

Refer to figures on page 11 to 15.

Note if unit is to be installed on a 25 degree tilt refer to page 11 for this type of installation.

1. Measure and locate holes to be drilled for mounting brackets into overhead beams or support. The PH-40, PH-40 HO and PH-75 HO have two (2) mounting locations, one at each end. The PH-50 & 75 have a third located in the center of the unit.
2. **FOR RIDGID INSTALLATION: READ WARNING ON PAGE 9 FIRST.**  
When installing fasteners such as bolts, inserts, threaded rod, etc, it is suggested that the fastener(s) are no less than 3/8 inch (.9525 cm) in diameter (two (2) per hanging point) and must penetrate and be secured in the overhead material in such a way that the unit will not be dislodged from the mounting location during normal use and operation, including wind load. This is the responsibility of the installing contractor and if in doubt, they shall contact the manufacturer of the fastener chosen to verify its use.  
**(See WARNING on page 9)**
3. Lift and support preassembled unit in a safe manner, and locate where heater is to be installed. Install fasteners through hanging brackets (optional) into the mounting material (beam, support etc.). Then attach heater to the brackets. PH-40, 40 HO & 75 HO are now mounted. In the case of the PH-50 & 75, the last section will have to be installed to the mounted, preassembled, first 10'. (see item #5)
4. **CHAIN INSTALLATION: DO NOT USE IN WINDY CONDITIONS - READ WARNING ON PAGE 9 FIRST.**  
Adequately secure hanging chains as mentioned in the above item #2. Drop chains to desired elevation and attach heater to them utilizing two lengths per hanging point.
5. PH-50 & 75: Unassembled parts. Secure end cap to one end of the reflector by overlapping reflector onto end cap 3/4 inch, (1.905 cm) (see page 13) and secure via self tapping screws.
6. Attach the reflector assembly to the 10' (3m) section already mounted by overlapping the opposite reflector end onto the hanger assembly by 3/4 inch. (1.905 cm). Secure hanger on end cap end via fasteners into the previously drilled holes located in the beam, support etc. Secure opposite end of reflector to hanger via self tapping screws.
7. Install radiant tube by positioning three (3) inch (7.62 cm) end into end cap from below, and butting the other end to the previously installed section. Secure clamp with self tapping screws (see figure 9 page 13). For PH-50 tube slides over the first 10' (3m) section tube. Secure with screws.
8. Install decorative grille (2 – 5' (1.53m) pieces) onto lip of reflector in a similar fashion used to install 2 x 4 ceiling panels. If need be, remove some of the screws securing the reflector to the hanger and/or end cap, spread reflector to facilitate installation, being careful not to damage reflector, install grille and re-secure the reflector.
9. Install retaining clips (6 per section of screen)
10. If installing models PH-40, 50 or 75 indoors, attach venting as per pages 15B, 15C, 15D and 15E. NOTE: PH40HO and PH75HO models cannot be vented. See page 15A for Ventilation requirements to make sure you have the correct heater for your application.
11. Connect gas, electricity, and mount controls in a convenient location.
12. Follow guidelines for startup on page 24.

# SUSPENSION DETAILS

## CHAIN MOUNTING

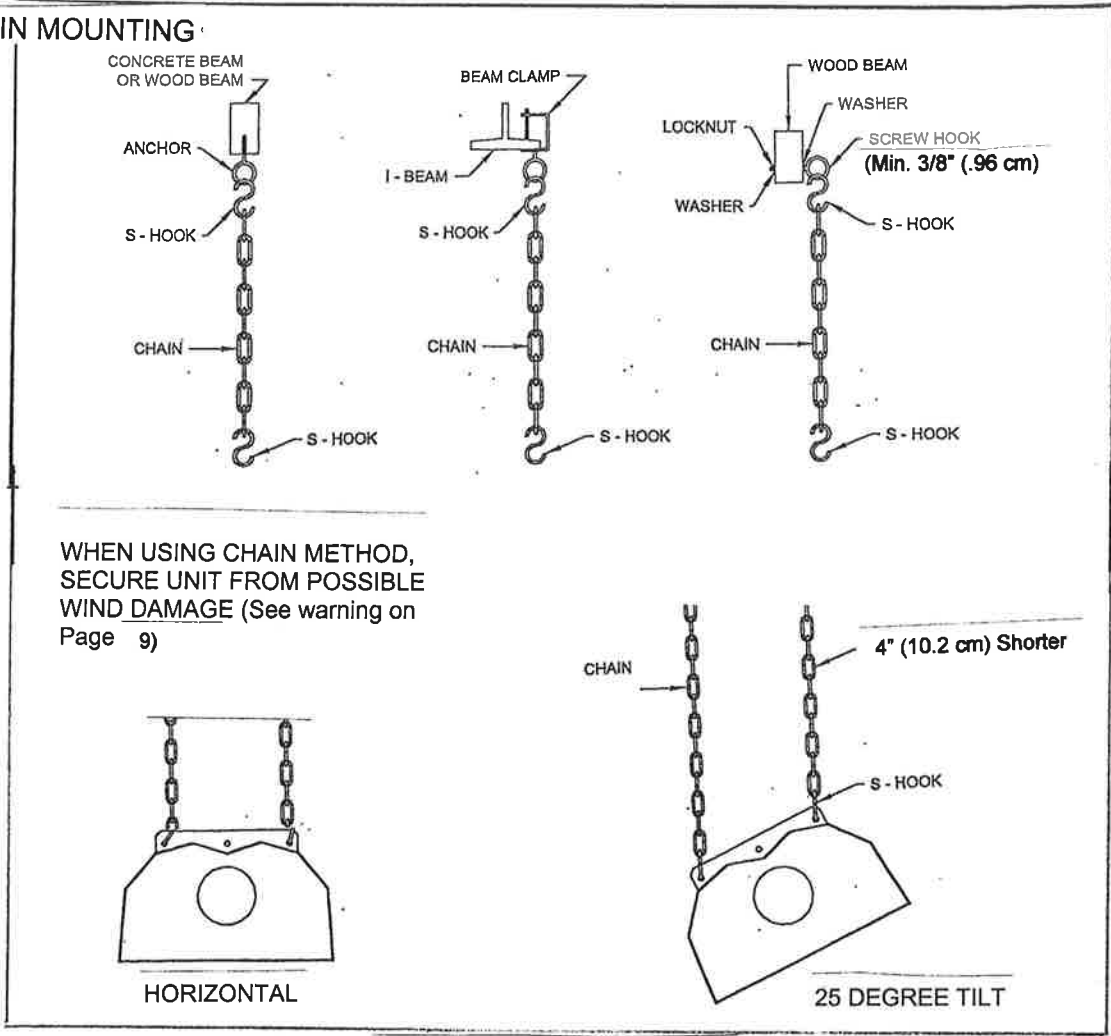

FIGURE #5 CHAIN MOUNTING

## RIDGID MOUNTING

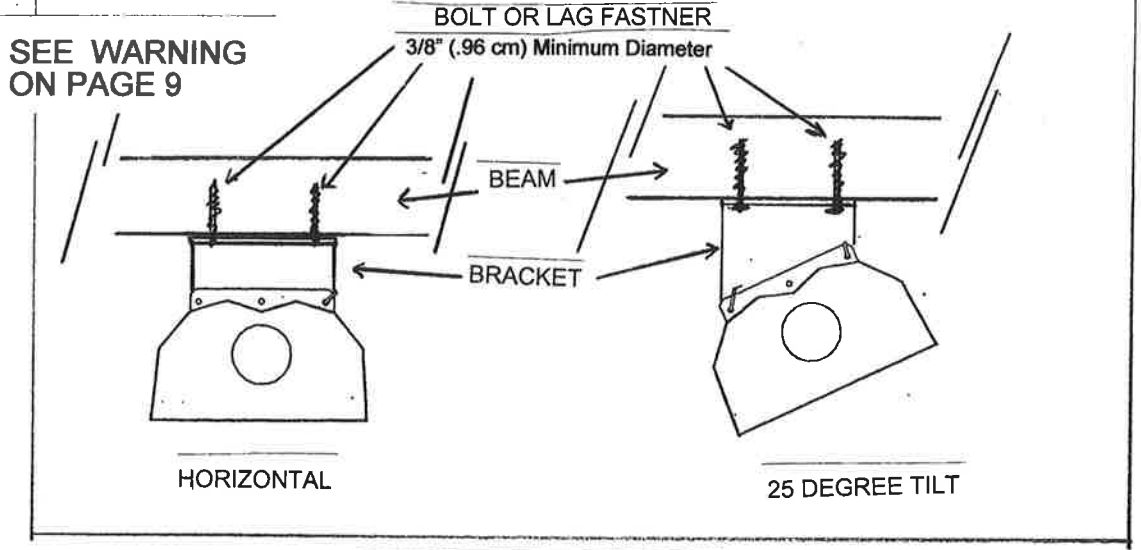

FIGURE #6 RIDGID MOUNTING

**ASSEMBLY**  
-PH-50  
-PH-75

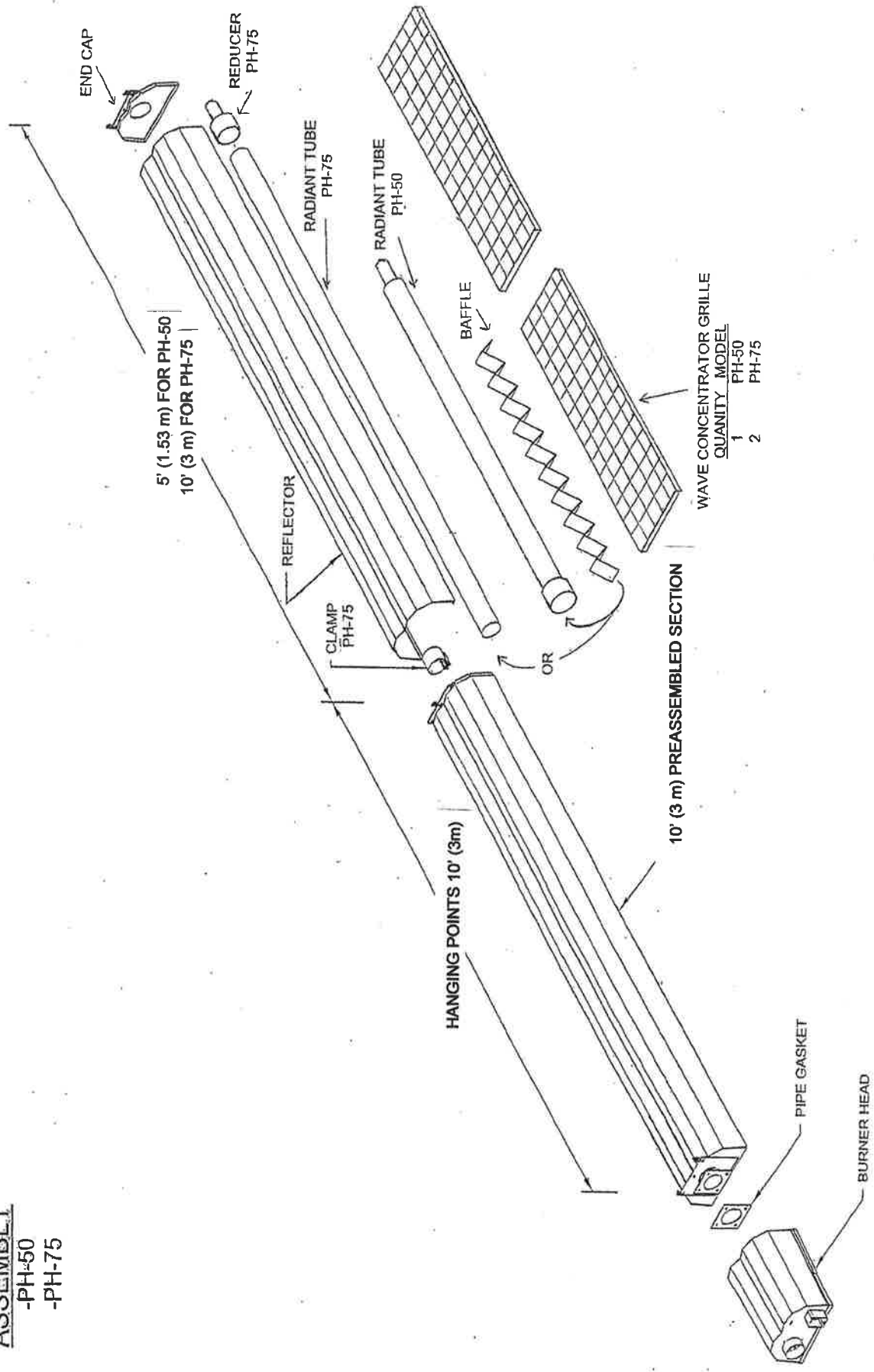

FIGURE #7. PH-50 & 75 ASSEMBLY



### JOINT HANGER TO REFLECTOR (PH-50 & 75 MODELS)

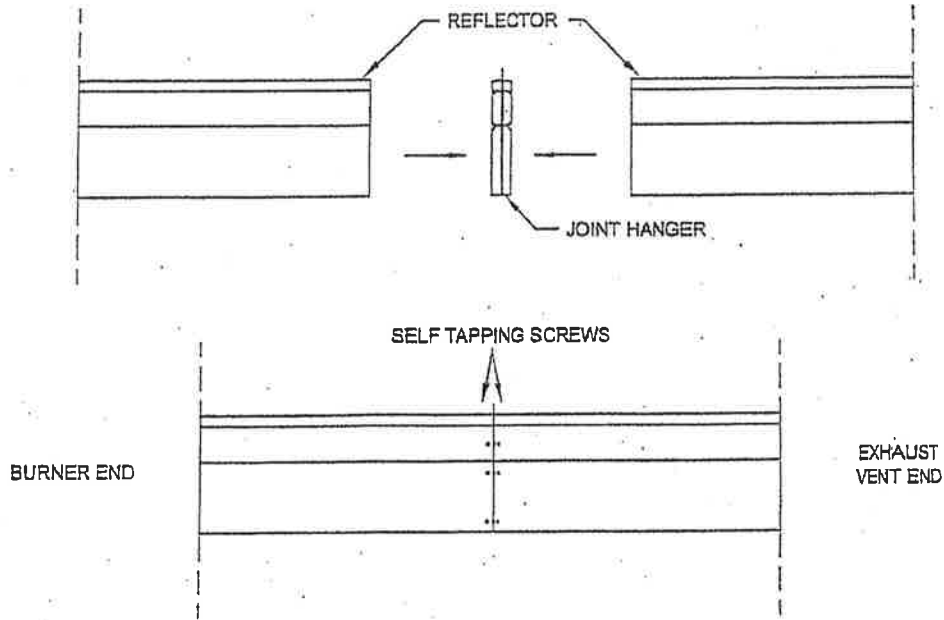

FIGURE #8. JOINT HANGER INSTALLATION

### CLAMP COULPER

(PH-50 & 75 MODELS)

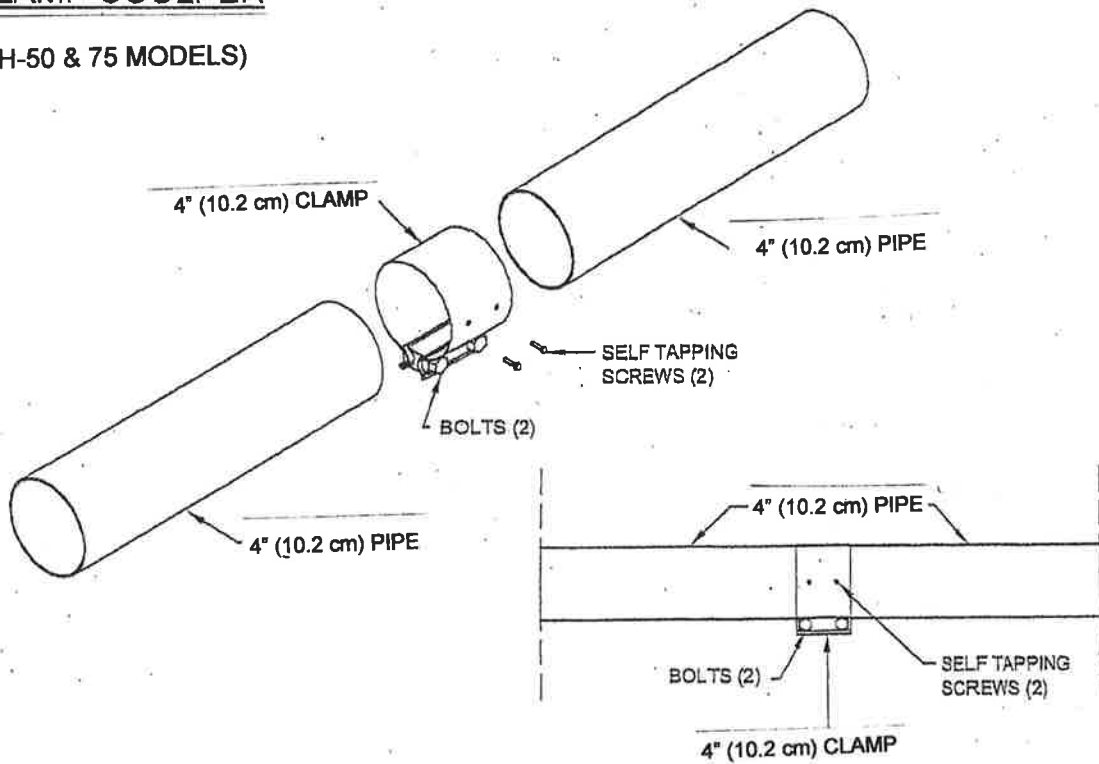

FIGURE #9. CLAMP COUPLER INSTALLATION

END CAP TO REFLECTOR  
(PH-50 & 75 MODELS)

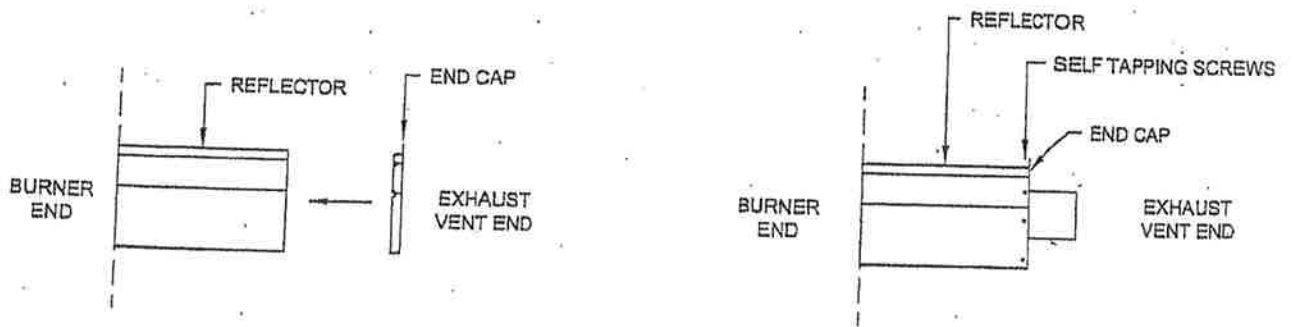

FIGURE #11. END CAP INSTALLATION

### 90° ELBOW KIT

(PH-50 & 75 MODELS)

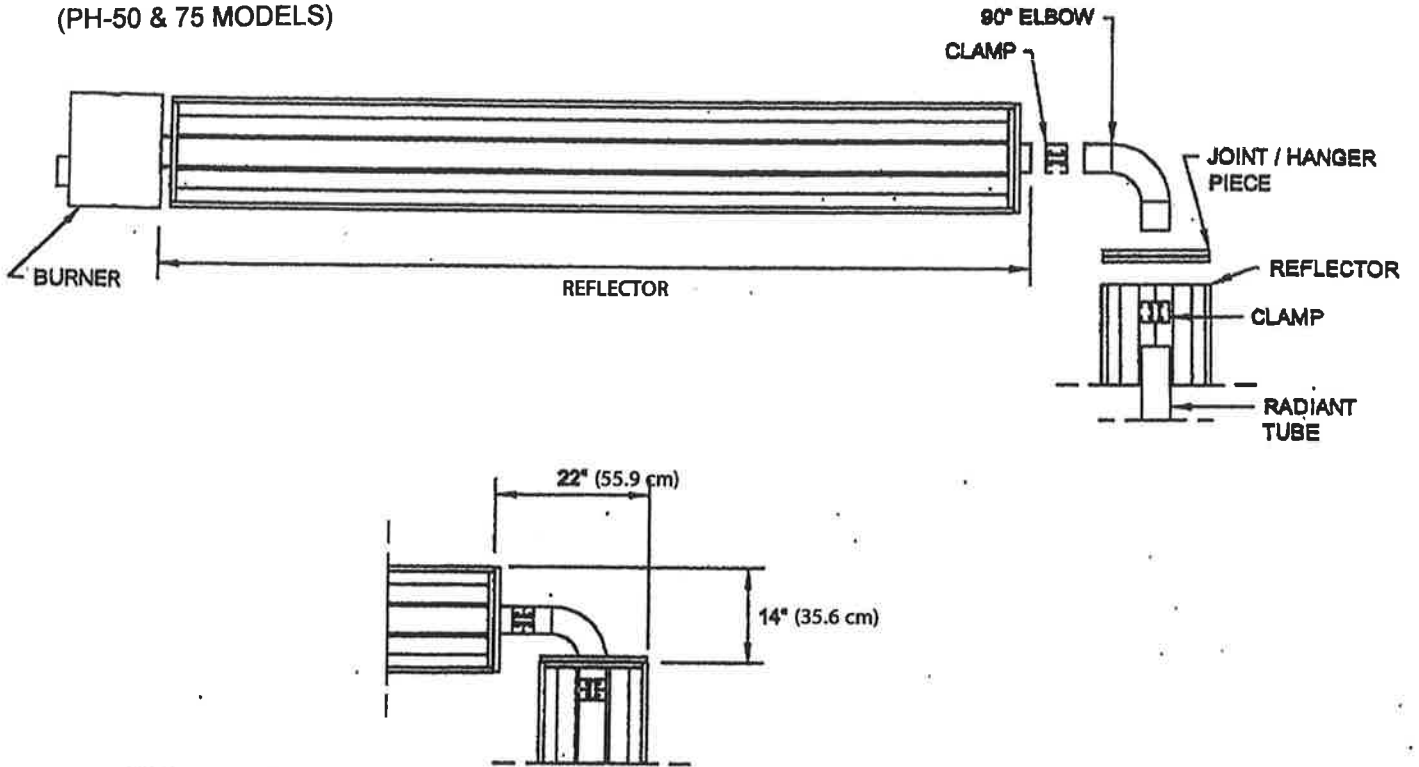

FIGURE #12 90° ELBOW KIT INSTALLATION

### 180° U - BEND KIT

(PH-50 & 75 MODELS)

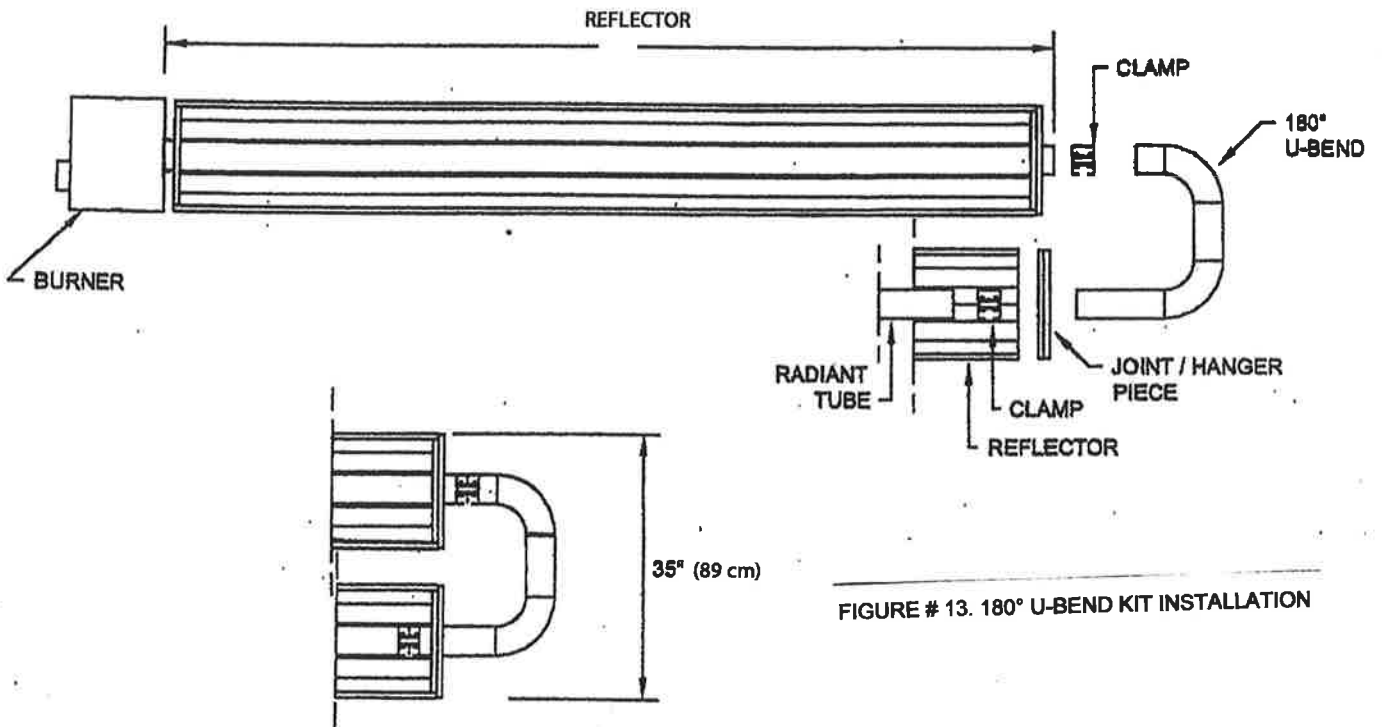

FIGURE # 13. 180° U-BEND KIT INSTALLATION

### **UNVENTED APPLICATIONS: (All Models)**

This appliance shall only be used in a well vented space and shall not be used in a building, garage or any other enclosed or semi enclosed space unless the space conforms to the specifications under the sections titled: “.FOR UNVENTED INSTALLATIONS IN SEMI ENCLOSED APPLICATIONS” or “.FOR VENTED INSTALLATIONS “

If no other means of ventilation is provided (either mechanical or natural ventilation) in the area to be heated, an appliance may be installed with shelter no more inclusive than:

- a) With walls on all sides, but no overhead cover.
- b) Within a partial enclosure which includes an overhead cover and no more than two side walls. These side walls may be parallel, as in a breezeway, or at right angles to each other.
- c) Within a partial enclosure which includes an overhead cover and three side walls, as long as 30 percent or more of the horizontal periphery of the enclosure is permanently open.

### **FOR UNVENTED INSTALLATIONS IN SEMI ENCLOSED APPLICATIONS : (All models)**

If the heater is to be used or installed in a semi enclosed application, which is more confining than as described under the section titled “UNVENTED APPLICATIONS” but is not totally enclosed; adequate ventilation must be provided to dilute the products of combustion. This rate is a minimum of four (4) CFM (cubic feet per minute) or .12 cubic meters per 1000 BTU/Hr of installed heater input. Ventilation is to be provided via mechanical or natural gravity (convection). Provision must be provided for adequate fresh, outdoor air to enter the space through either, building crack-age and/or fresh air ventilation inlets and/or mechanical exhaust and/or supply fans. Contact local authorities for verification of local code compliance prior to operation.

If adequate ventilation cannot be provided, a condition can occur whereby the exhaust gases can displace the available air at ceiling level to such an extent that the heater may not operate properly and cause one or all of the following symptoms: black residue at the exhaust outlet (soot) and /or backfiring and/or complete heater shutdown. In order to eliminate this possible condition, do not install this heater in recessed ceiling applications that are not ventilated (if clarification of this type of installation is required, call the factory for further information prior to installation or purchase), or in situations where the products of combustions cannot escape or be ventilated at a rate sufficient to support combustion. Ventilation in tray ceiling or peak ceiling applications can be via mechanical ventilation, or natural convection through ventilation and exhaust inlets or grilles at a minimum rate of four (4) CFM (cubic feet per minute) or .12 cubic meters per 1000 BTU/Hr of installed heater input.

**If you do not understand or are unfamiliar with the terminology or instruction as they are written, do not install this product until you contact the local authorities for clarification or approval.**

### **FOR VENTED INSTALLATIONS: (For PH -40A, 50A and 75A models only)**

**⚠ WARNING: DO NOT ATTEMPT TO CONNECT ANY HO (HIGH OUTPUT) MODEL TO ANY VENTING.**

If adequate ventilation cannot be provided by the methods previously described under the heading “FOR UNVENTED INSTALLATIONS IN SEMI ENCLOSED APPLICATIONS”, an approved chimney or sidewall venting system must be used. **Only models PH-40A, 50A and 75A can be connected to an approved venting system.**

If you have an HO model and cannot provide adequate ventilation to safely operate the unit as per the previous heading (“FOR UNVENTED INSTALLATIONS IN SEMI ENCLOSED APPLICATIONS”), return unit to your supplier and purchase the appropriate model for this type of application.

If you do not understand or are unfamiliar with how to vent a gas fired appliance, do not install this product until you contact the local authorities for clarification or approval.

To connect to an approved chimney (by others) or side wall vent system (Part #800208) remove the exhaust hood from the end cap by drilling out four (4) retaining rivets and discarding the hood. The exposed tubing is 3” I.D. and can be connect to an approved venting system by following the instructions on appropriate pages (15-B to 15D) for your particular installation.

If the roof/chimney type installation is selected also adhere to any instructions supplied by the manufacturer of the system.

(Refer to pages 15C – 15E)

Venting of the unit(s) must comply in Canada with the **Natural Gas and Propane Installation Code, CSA B149.1** or latest edition and in the USA, the **National Fuel Gas Code, ANSI Z223.1/NFPA 54** or latest edition. In Canada, vent terminal clearances shall be in accordance with the Canadian **CSA B149.1, Natural Gas and Propane Gas Installation Code**.

A) Select exhaust vent point:

A vent shall not terminate:

- 1) within 6 feet (1.9m) of a mechanical air supply inlet to a building;
- 2) above a meter/regulator assembly within 3 feet (92cm) horizontally of the vertical line of the regulator;
- 3) within 6 feet (1.9m) of any gas service regulator vent outlet;
- 4) less than 1 foot (31 cm) above grade level'
- 5) less than 7 feet (2.2) above a paved sidewalk or a paved highway;
- 6) within 3 feet (92 cm) of a window or door which can be opened in any building, any non-mechanical air supply inlet to any building or the combustion air inlet or any other appliance.

NOTE: Maybe reduced to 1 foot (31cm) for inputs up to 100,000 Btu/hr (30kw) and 3 feet (1m) for inputs exceeding 100,000 Btu/hr

In the USA, the **National Fuel Gas Code, ANSI Z223.1/NFPA 54**, specifies a 4 ft (1.22 m) horizontal vent terminal clearance from gas and electrical meters, regulators and relief equipment.

Clearances are to be in accordance with local installation codes and the requirements of the gas supplier.

- B) For horizontal, sidewall venting a single unit use side wall vent kit PIN #800208 (see page 15C). The heater must not be connected to a separate chimney, but must be installed using the venting system approved for the heater and as supplied by the manufacturer of the heater. NOTE: Maximum length is 15' (4.6 m) including two (2) 90° elbows. Deduct 10' (3m) for every additional 90° elbows and 5' (1.53 m) for every 45° elbow.
- C) If roof exhaust; then use "B" style chimney. (see pages 33))
- D) Vent terminal must be at a height sufficient to prevent any blockage by snow for your area where this product is installed.
- E) Protect building materials from any degradation that may be caused by flue gases.
- F) Adequately support vent to prevent sagging in a manner that is in accordance with local codes for your area.
- G) Make sure that all flue joints are sealed. Use only suitable products equal to General Electric RTU106 or Permatex Form a Gasket Red High Temperature Silicone Adhesive Sealant (not included)
- H) If condensation in venting is present then venting should be insulated or shortened. In Canada, install according to the **Natural Gas and Propane Installation Code, CSA B149.1** or latest edition and in the USA, the **National Fuel Gas Code, ANSI Z223.1/NFPA 54** or latest edition.
- I) NOTE: For venting of two or more heaters into one common chimney, in Canada refer to the **Natural Gas and Propane Installation Code, CSA B149.1** or latest edition and in the USA, the **National Fuel Gas Code, ANSI Z223.1/NFPA 54** or latest edition.
- J) NOTE: A small amount of condensation may occur from the heater when it starts the heating cycle. The condensation should stop once the heater warms up. Make sure venting is sealed as previously noted.



**OPTIONAL VERTICAL VENTING**  
**(PH-40, 50 & 75 ONLY)**

(SIDE VIEW)

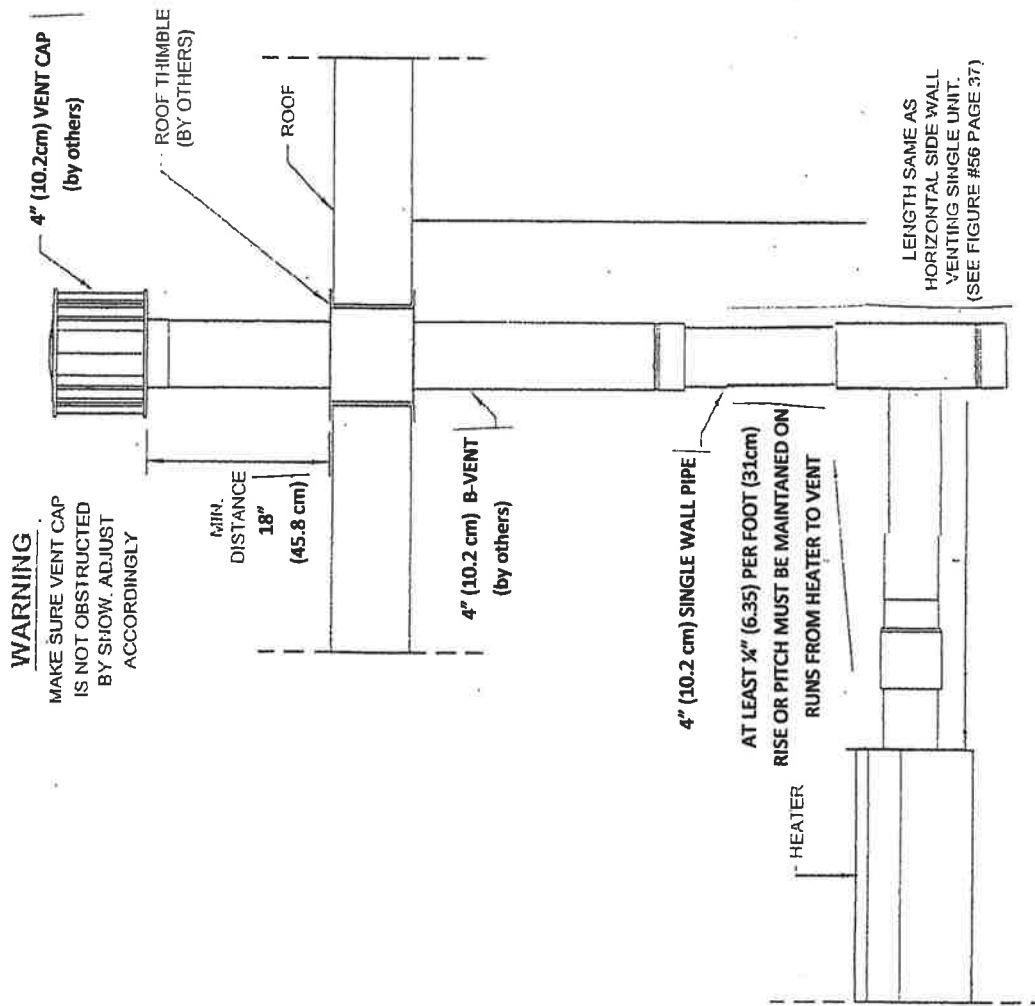
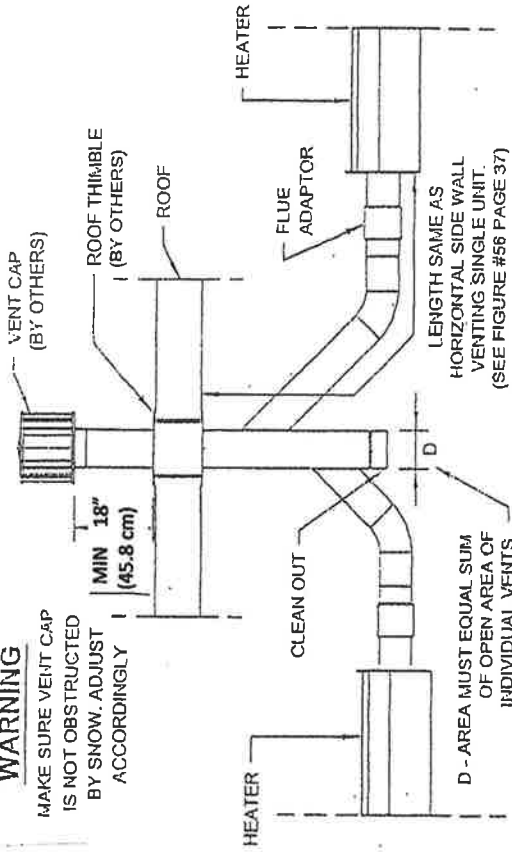

FIGURE #31. VERTICAL VENTING, SINGLE UNIT

**OPTIONAL COMMON VERTICAL VENTING  
(PH-40, 50 & 75 ONLY)**

**WARNING**

MAKE SURE VENT CAP IS NOT OBSTRUCTED BY SNOW. ADJUST ACCORDINGLY



(SIDE VIEW)

**NOTE**

UNITS THAT ARE COMMONLY VENTED MUST BE CONTROLLED BY THE SAME LINE VOLTAGE THERMOSTAT

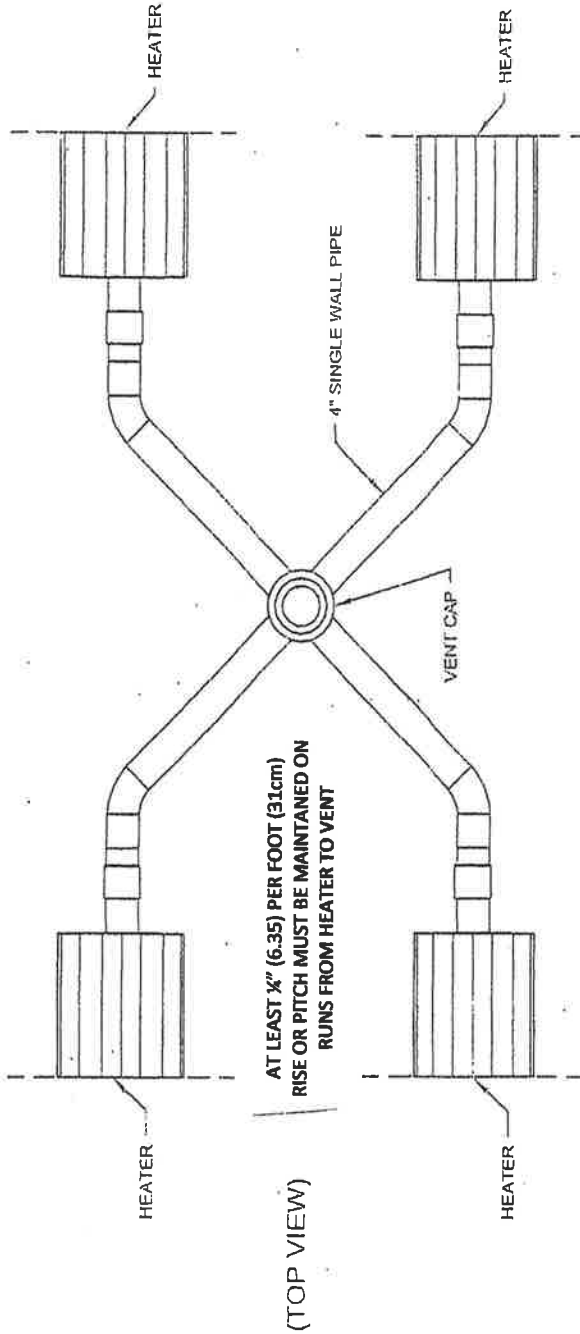

AT LEAST 1/4" (6.35) PER FOOT (31cm) RISE OR PITCH MUST BE MAINTAINED ON RUNS FROM HEATER TO VENT

(TOP VIEW)

FIGURE #32 - COMMON VERTICAL VENTING, TWO OR MORE UNITS INTO ONE COMMON VENT



## GAS PIPING

**⚠ WARNING:** All gas work **MUST** be performed by qualified/licensed personnel with adequate training and experience in this field.

**⚠ WARNING:** Use only the type of gas for which the heater is equipped. Using the wrong gas could create a hazard, resulting in damage, personal injury or death.

In Canada refer to the **Natural Gas and Propane Installation Code, CSA B149.1** or latest edition and in the USA, the **National Fuel Gas Code, ANSI Z223.1/NFPA 54** or latest edition.

- a) Adequate supply of gas to the heater is required for it to produce the designed amount of heat output. The gas meter must have a large enough capacity to handle the extra consumption required by the heater.
- b) The gas line must be of an adequate size to deliver the necessary amount of fuel to the unit.
- c) If there is any question concerning a) or b) call your local gas company for further assistance.
- d) Make sure that all piping is supported properly.
- e) All connections must have special sealing compound applied to them.
- f) A drip leg must be installed before the heater to prevent contaminating matter interfering with the operation of the unit.
- g) Check piping for leaks via pressure test. **Install a 1/8" (3.175 mm) N.P.T. plugged tapping** immediately ahead of heater in gas supply. Use this location for test gauge. A soap and water test can be used to verify location of any possible leak.

**⚠ WARNING:** Do not use an open flame for testing!

**⚠ WARNING:** For high pressure testing, disconnect heater(s) and shut-off cocks and cap off pipe for test. Failure to do so will damage pressure ratings on the above mentioned equipment and cause a complete replacement of these parts.

**WARNING**

The heater and its individual shutoff valve must be disconnected from the gas supply piping system during any pressure testing for that system at test pressures in excess of  $\frac{1}{2}$  psig.

The heater must be isolated from the gas supply piping system by closing its individual manual shutoff valve during any pressure testing of the gas supply piping system at test pressures equal to or less than  $\frac{1}{2}$  psig.

---

Refer to pages 18 & 19 for gas connection to heater.

## GAS CONNECTION

THE HEATER CAN BE CONNECTED TO THE GAS PIPING SYSTEM ONE OF THE FOLLOWING TWO (2) METHODS.

### #1 HARD PIPE

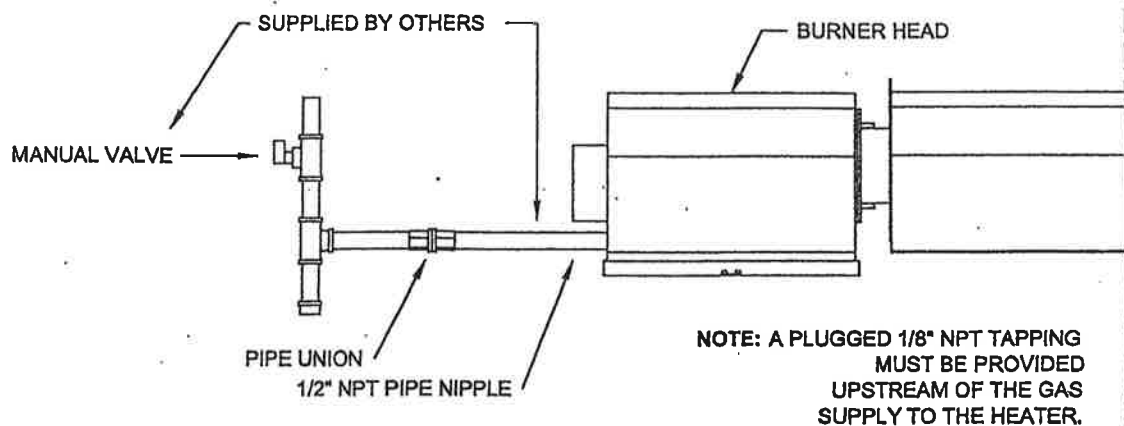

FIGURE #14 HARD PIPE INSTALLATION

### #2 FLEX CONNECTOR

WARNING:

FIRE AND/OR EXPLOSION HAZARD

*Can cause property damage, severe injury or death*

With each firing cycle, the radiant pipe will expand and contract which can cause the burner head to move horizontally with reference to the gas supply line. If the gas connection is not installed in strict accordance as shown in figure 17, a gas leak can occur resulting in an extreme unsafe condition.

" Certified connectors are recommended to be installed as shown, (figure 15 page 19 1) in one plane, and without sharp bends, kinks, or twists. The gas take off must be parallel to the burner gas inlet connection."

(CSA)

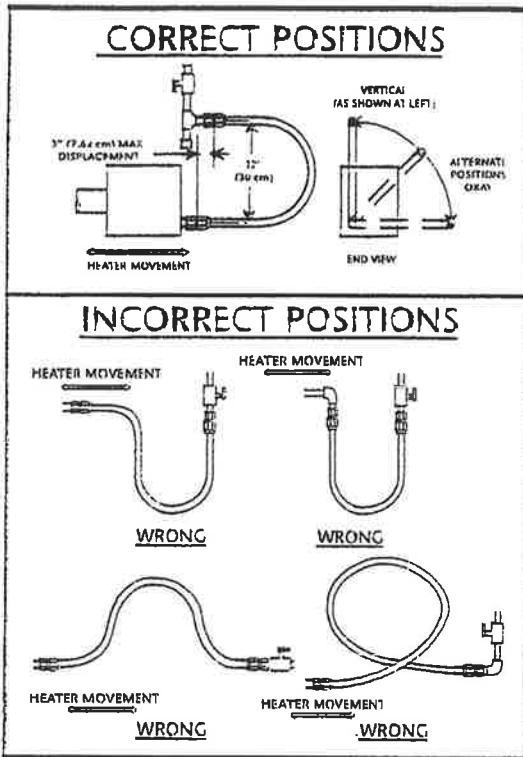

**Installation Position Instructions**

**Connector Installation**

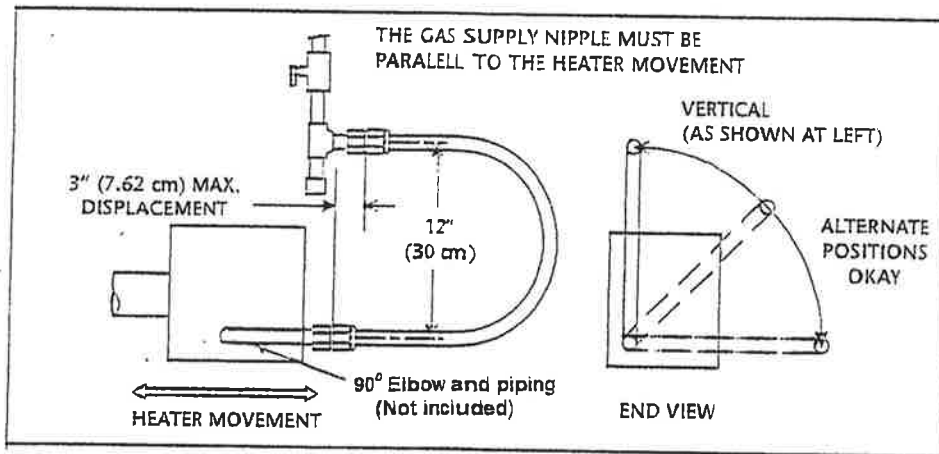

**⚠ WARNING:**

CONNECTOR MUST BE INSTALLED AS PER THE CONFIGURATION ILLUSTRATED ABOVE. USE ONLY THE 36" (90 cm) CONNECTOR OF 1/2" (1.27 cm) NOMINAL ID FOR LENGTHS FROM 10' (3m) TO 70' (21.3 m) AND A 36" (90 cm) CONNECTOR OF 3/4" (1.905 cm) NOMINAL ID FOR LENGTHS GREATER THAN 70' (21.3m).

IN CANADA: "A radiant tube-type infrared heater shall only be connected with a Type 1 hose connector that is (a) certified as being in compliance with the Standard for Elastomeric Composite Hose and Hose couplings for Conducting Propane and Natural Gas, CAN/CGA 8.1 and (b) of a length of 36 +/- 6" (90 +/- 15 cm)."

IN USA: Flexible Metallic connectors must be certified for use on a radiant tube-type infrared heater as per the Standard for Connectors for Gas Appliances, ANSI Z21.24/CSA 6.10. Connector is available from manufacturer.

FIGURE #15 GAS LINE CONNECTION WITH CERTIFIED FLEXIBLE GAS CONNECTION

## ELECTRICAL CONNECTION 120 VOLTS

Refer to rating plate on heater for electrical specifications.

Supply adequate, grounded electrical power supply to heater via watertight, outdoor rated electrical wiring. Fasten ground wire to grounding lug on frame of burner head and connect 120 volts to the black and white pigtail wires from the transformer.



### WARNING



DO NOT operate heater until it has been thoroughly installed, inspected and is ready for initial fire-up.

**NOTE:** All connections and wiring must be made in accordance with CSA C22.1 CANADIAN ELECTRICAL CODE PART 1 as well as/or local codes, conditions and authorities. Refer to wiring diagrams on pages 23. In the USA refer to NATIONAL ELECTRIC CODE ANSI/NFPA 70-1987 or most current edition.

**NOTE:** If any of the original wire supplied with the unit must be replaced do so only with material having at least 105 degrees centigrade temperature rating.

The heater, when installed, must be electrically grounded in accordance with local codes or, in the absence of local codes, with ANSI/NFPA 70.

DO NOT use an extension cord as the electrical source for the heater.

### REMOTE CONTROL PANEL

(Low voltage connection)

Locate low voltage controller in convenient location. Connect multi-strand, low voltage wires to panel. Secure wiring accordingly and make final connection inside heater burner box compartment making sure that the correct number on the terminal strip matches identically with the color wires on the Hi/Lo switch. The terminals for the on/off switch, 3 and 4, are not location specific but must be wired only to 3 and 4 in the burner head.

**ONLY USE APPROVED OUTDOOR WIRE.**

Use 18 gauge for distances up to 50' and 16 for distances greater than 50 feet.

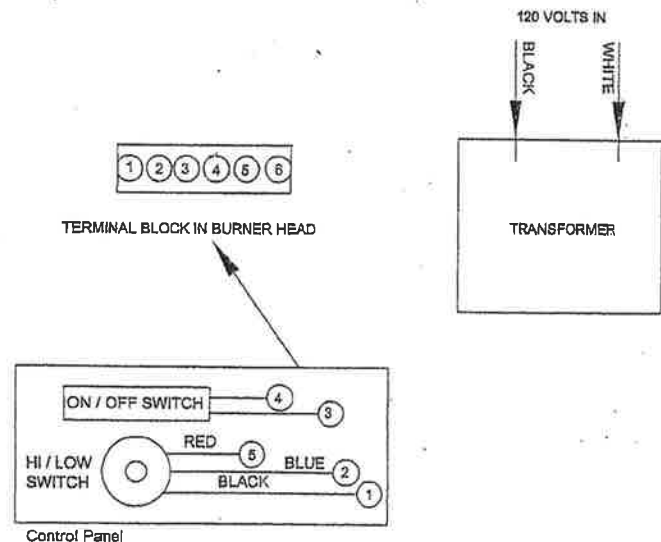

FIGURE #16. ELECTRICAL CONNECTIONS 120 VOLT

**MODELS PH-40, 50 & 75 ONLY:**

**THERMOSTAT CONNECTION:**

USE THERMOSTAT EQUAL TO: HONEY WELL LINE VOLTAGE MODEL T4098A or T410A. INSTALLED SUCH THAT THE THERMOSTAT CONTROLS THE VOLTAGE BEING SUPPLIED TO THE UNIT.

If any of the original wire supplied with the unit must be replaced do so only with material having at least 105 degrees centigrade temperature rating.

<b>Calcana Industries Ltd.</b>	
<b>Wiring Diagram</b>	
Description	Ph
Series	All Modulating 120 volt units
Model	N/A
Material	N/A
Tolerance	N/A
Drawing #	WM120

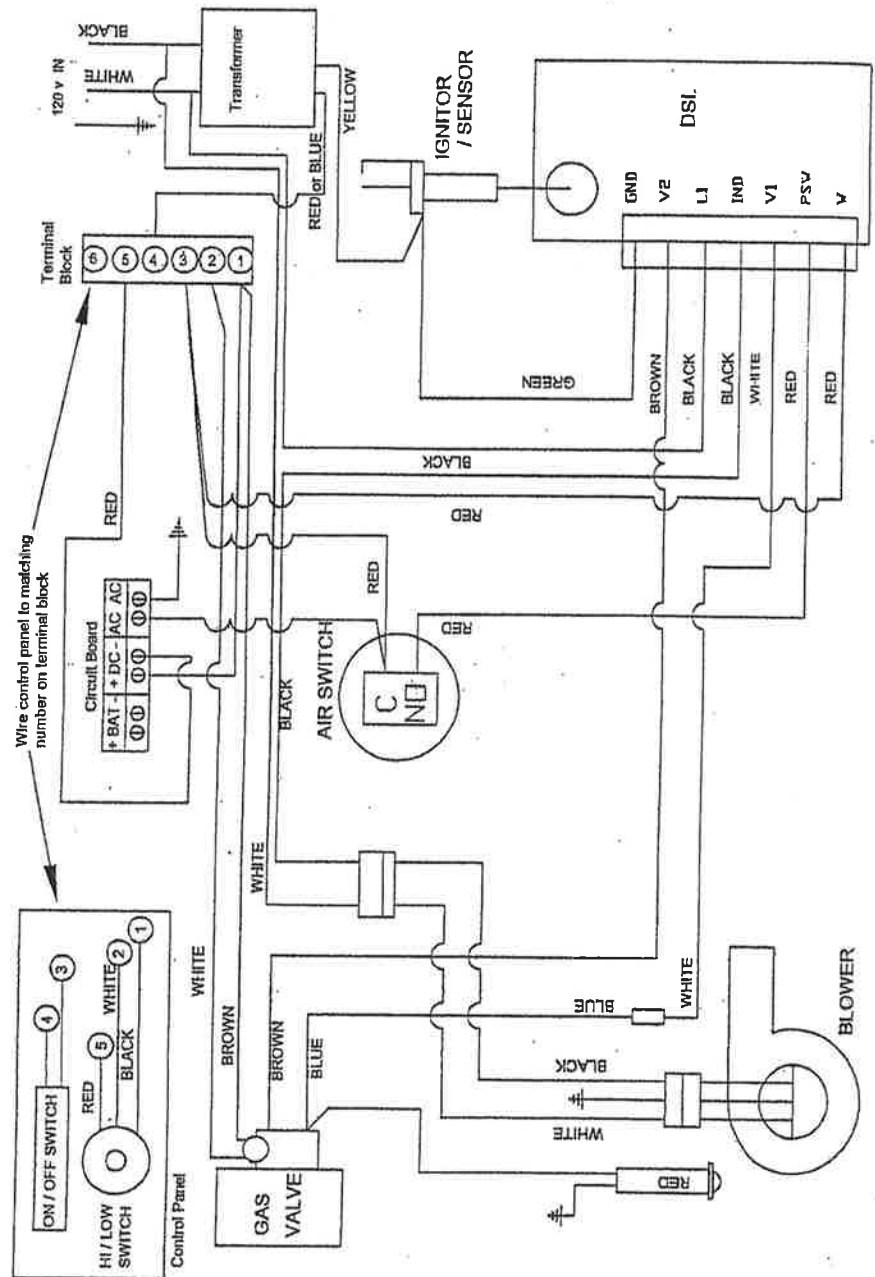

**MODELS PH-40, 50 & 75 ONLY:**  
**THERMOSTAT CONNECTION:**  
 USE THERMOSTAT EQUAL TO: HONEY WELL LINE VOLTAGE  
 MODEL T4098A or T410A. INSTALLED SUCH THAT THE  
 THERMOSTAT CONTROLS THE VOLTAGE BEING SUPPLIED TO THE UNIT.

FIGURE #17. WIRING DIAGRAM 120 VOLT

**ELECTRICAL CONNECTION 24 VOLT (Alternate power supply)**

- 1) Locate 24 VAC volt transformer near 120 volt source.
- 2) Supply wire from transformer to heater must have adequate capacity and insulation temperature ratings for total connected load. Use 18 gauge wire from transformer to heater for distances up to 50 feet. For distances greater than 50 feet use 16 gauge.
- 3) If any of the original wire supplied with the unit must be replaced do so only with material having at least a 105 degrees Centigrade temperature rating.
- 4) All connections and wiring must be made in accordance with CSA C22.1 CANADIAN ELECTRICAL CODE PART 1 as well as/or local codes, conditions and authorities. Refer to wiring diagrams on page 23. In the USA, refer to the NATIONAL ELECTRICAL CODE ANSI/NFPA 70-1987 or most current edition

**WARNING**

DO NOT operate heater until it has been thoroughly installed, inspected and is ready for initial fire-up.

**REMOTE CONTROL PANEL**

**(Low voltage connection)**

Locate low voltage controller in convenient location. Connect multi-strand, low voltage wires to panel. Secure wiring accordingly and make final connection inside heater burner box compartment making sure that the correct number on the terminal strip matches identically with the color wires on the Hi/Lo switch. The terminals for the on/off switch, 3 and 4, are not location specific but must be wired only to 3 and 4 in the burner head.

**ONLY USE APPROVED OUTDOOR WIRE.**

Use 18 gauge for distances up to 50' and 16 for distances greater than 50 feet.

**24 VAC POWER SUPPLY**

Connect to terminal leads #4 and #6 inside burner box.

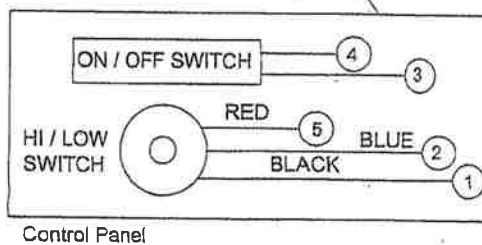
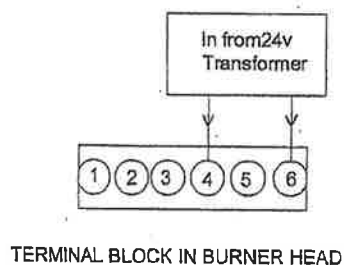

FIGURE #18. ELECTRICAL CONNECTIONS 24 VOLT

**MODELS PH-40, 50 & 75 ONLY:**

**THERMOSTAT CONNECTION:**

USE THERMOSTAT EQUAL TO: HONEY WELL LINE VOLTAGE MODEL T4098A or T410A. INSTALLED SUCH THAT THE THERMOSTAT CONTROLS THE VOLTAGE BEING SUPPLIED TO THE UNIT.

If any of the original wire supplied with the unit must be replaced do so only with material having at least 105 degrees centigrade temperature rating.

Calcana Industries Ltd.	
Wiring Diagram	
Description	Ph
Series	All Modulating 24 volt units
Model	N/A
Material	N/A
Tolerance	N/A
Drawing # WM24	

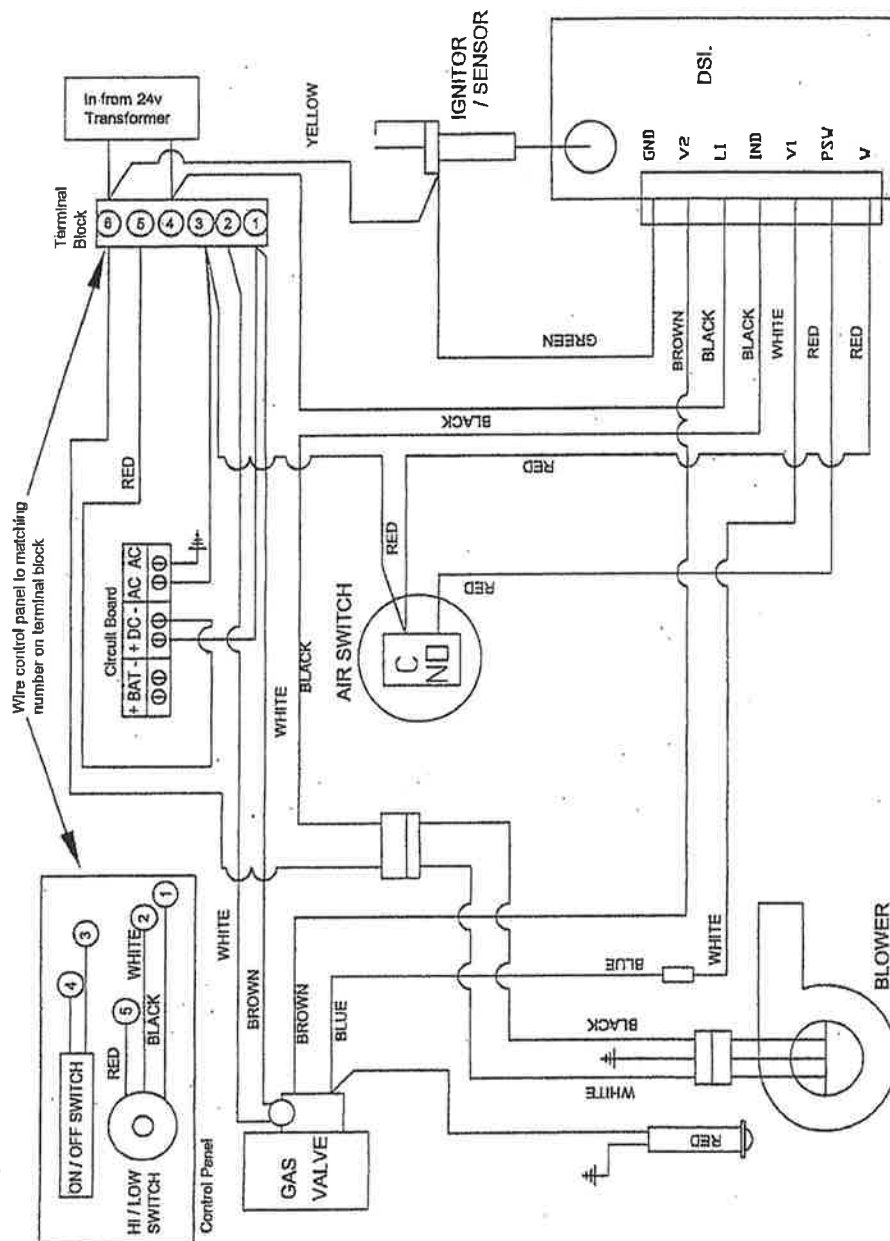

**MODELS PH-40, 50 & 75 ONLY:**

**THERMOSTAT CONNECTION:**

USE THERMOSTAT EQUAL TO: HONEY WELL LINE VOLTAGE MODEL T4098A or T410A. INSTALLED SUCH THAT THE THERMOSTAT CONTROLS THE VOLTAGE BEING SUPPLIED TO THE UNIT.

FIGURE #19. WIRING DIAGRAM 24 VOLT



## INITIAL START-UP



**IMPORTANT NOTICE:** This heater is not to be used as a construction heater to supply heat to an unfinished building during the finishing phases of construction. This practice exposes the unit to an abnormally corrosive atmosphere from sources such as paint, varnish and adhesives, which can lead to premature radiant tube exchanger or vent failure. The practice also allows foreign materials such as sawdust or sheet rock dust to enter the combustion blower, burner, heat exchanger and vent system, resulting in shorter life of the unit.

**Use of the heater as a construction heater will void the warranty.**

### Procedure:

- a) Make sure gas is turned on.
- b) Check for any possible blockages in combustion air intake and exhaust areas of unit.
- c) Make sure all options are attached securely.
- d) Make sure electricity is on to unit.
- e) Turn control on/off switch to on.
- f) Check the flame port to see flame has established.
- g) If flame is not established, turn on/off switch to off for 5 seconds then turn back up or interrupt electrical supply to unit for 5 seconds, and allow unit to try again.
- h) Verify that the manifold pressure (outlet pressure tap) on the gas valve is the same pressure as stated on the rating plate of the unit. Use a manometer that measures inches of water column for this procedure. If adjustment is required, remove the capscrew from the pressure regulator housing. Adjust the pressure regulator adjusting screw according to instruction on page 25. Replace capscrew. After measurement has been taken, replace pipe plug in outlet pressure tap. Check for leaks. (see pages 3, 4 & 25)
- i) Verify gas input rate. (see page 26)

**NOTE:** Oil smoke might appear off of exchanger tube after it heats up initial firing. Do not be alarmed. The smoke is just a small amount of oil on the surface of the tube from manufacturing. If smoke is excessive, open door and 'air out' the building until smoke is removed.

**NOTE:** Heater will have higher heat output by the burner head as compared to the exhaust end. This is normal.

**NOTE:** A small amount of condensation may occur from the heater when it starts the heating cycle. The condensation will stop once the heater warms up.

VALVE DETAILS

- 1 Solenoids V1 + V2
- 2 Electrical connection V1/V2 Molex Serie 3000
- 3 Servo governor
- 4 Main gas outlet
- 5 Test nipple p<sub>1</sub>
- 6 Main gas inlet p<sub>1</sub>
- 7 Ignition gas outlet
- 8 Test nipple p<sub>2</sub>
- 9 Setting screw for governor with SW 2 socket head
- 10 Setting screw for start gas volume or slotted screwdriver
- 11 **only GB-GD...D01 and GB-N... D01**  
Signal p<sub>air</sub> connection
- 12 **only GB-GD...D01 and GB-N... D01**  
"Min" setting screw K (SW 2) 0-point offset
- 13 **only GB-GD...D01 and GB-N... D01**  
"Max" setting screw V (SW 2) Ratio adjustment
- 14 **GB-M... D01 only**  
Cover
- 15 **GB-M... D01 only**  
setting screw SW 3 Min
- 16 **GB-M... D01 only**  
setting screw SW 2 Max
- 17 **GB-M... D01 only**  
Modulator
- 18 **GB-M... D01 only**  
Modular power supply, Male connector AMP 6,3 x 0,8 mm
- 19 Solenoid retaining screw
- 20 Side cover with screws

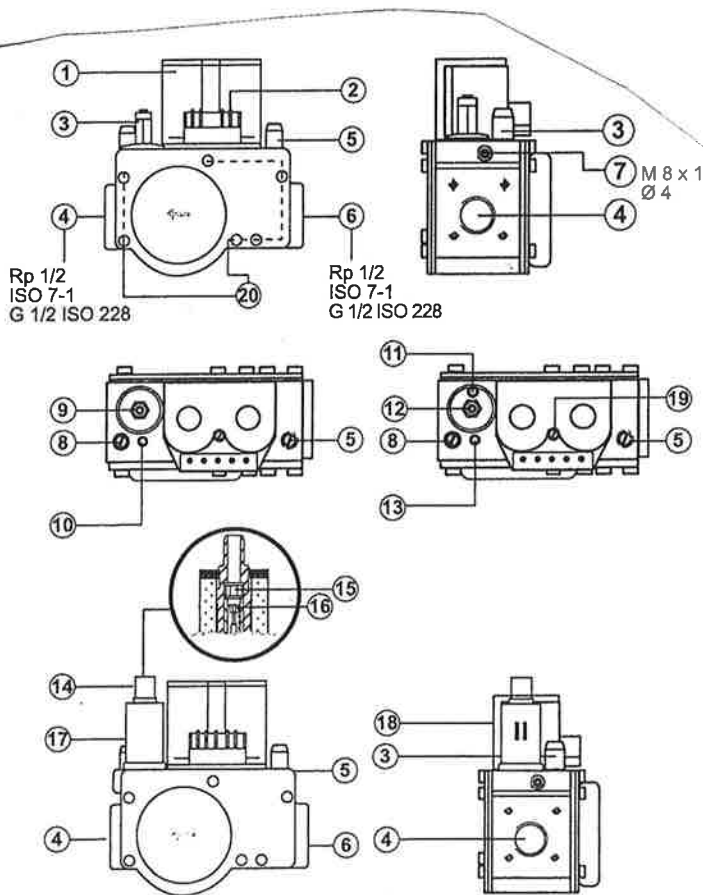

FIGURE #20 GAS VALVE

SETTING MANIFOLD PRESSURE

Setting the modulator

**⚠ Caution!**  
Always set Min first since Max is adjusted simultaneously!

Setting Min

A Remove electrical connection 18 from modulator

**⚠ Caution!**  
Do not use ball head tools with a 3 mm shaft. Otherwise Min is adjusted simultaneously!

B Set small load, setting screw 15 (use 3 mm socket head):

higher pressure  
counterclockwise

lower pressure  
clockwise

Setting Max

Operate Heater On HIGH

C Set Max, setting screw 16 (2 mm socket head)

60° corresponds to approx. 1 mbar

higher pressure  
counterclockwise



lower pressure  
clockwise

On completion of work on the GB-M... D01, perform a leakage and function test.

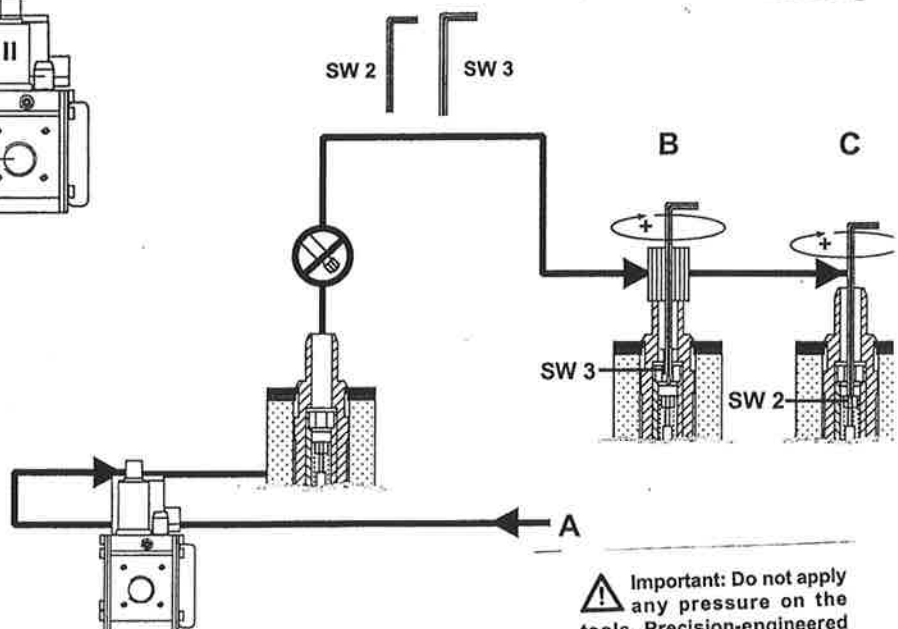
REFER TO RATING PLATE FOR MIN/MAX MANIFOLD PRESSURES





**⚠ Important!** Do not apply any pressure on the tools. Precision-engineered tools.

 **WARNING** 

Natural gas heating values can vary widely. It is the responsibility of the Installer to make sure that the input rate to the heater as installed does not exceed the nameplate rating of the heater. Failure to do so can cause radiant tube failure, resulting in injury or death.

The maximum BTUH input capacity for each model is shown on the heater's rating plate and in the specification table. This input must not be exceeded.

**The input shown may be used in geographic area where the elevation is from 0 to 4,500 feet (1372 m) above sea level (Canada only) in accordance with CGA 2.17-M91 (R2003), no change required to main orifice. For installations above 4,500 (1372 m) refer to *Natural Gas and Propane Installation Code, CSA B149.1* or latest edition, or contact the factory. In the USA: For installations above 2000 feet (610 m), the appliance shall be de-rated 4 percent (%) for each 1000 feet (305 m) of elevation above sea level. The Btu/hr input depends on the calorific heating value of the gas, orifice size, and manifold pressure. Orifice sizes are based upon values of 1000 Btu/hr/cu. ft (.028316 cubic meter) and 2500 Btu/hr/cu. ft. (.028316 cubic meter) for L.P.G. (propane)**

 **WARNING** 

NEVER ATTEMPT TO MODIFY THIS HEATER — FIRE, EXPLOSION, OR ASPHYXIATION MAY RESULT. If malfunction is apparent, contact qualified service agency and/or gas utility for assistance.

**How to Determine Gas Input Rate:**

Where gas is metered, the input rate may be determined by the following method; Contact the gas supplier, public utility company or LP (propane) gas distributor to obtain the calorific gas value of the gas being used. When checking the gas input rate, any other gas burning appliances connected to the same meter must be completely off. The heater should be allowed to operate for 5 minutes before attempting to check the gas input rate.

To check flow rate, observe the one cubic foot dial on the gas meter and determine the number of seconds required for the dial hand to complete one revolution (seconds to flow one cubic foot).

To determine the number of seconds per cubic foot that is necessary to achieve the correct input rate, use the following formula:

$$\text{GAS VALUE X 3600/ DESIRED INPUT= SECONDS NEEDED}$$

Example: 1000 BTU gas, heater input 100,000 BTUH

Seconds for one cubic foot =  $1000 \times 3600 / 100,000 = 36$  seconds

If when clocking the meter, the one cubic foot dial makes a complete revolution in less time than was calculated that it should be derated. If it takes more time for the meter to make one revolution than was calculated, the unit is underfired.

The orifice size must be changed to correct an overfired or underfired condition. If it is determined that different orifices are needed, please contact your distributor for assistance in selecting the correct replacement.

## **SEQUENCE OPERATION**

### **DESCRIPTION OF 3-TRY DIRECT SPARK IGNITION SYSTEM:**

The TRITON 2461D is a 24 VAC Microprocessor Based Direct Spark Ignition Control designed for use in all types of heating applications such as gas furnaces, boilers, water heaters and other similar appliances. The control utilizes a microprocessor to continually and safely monitor, analyze and control the proper operation of the gas burner. Value added features such as combustion blower control, LED diagnostics, automatic one hour reset, and flame current test pins highlight the controls benefits.

### **OPERATION:**

#### **POWER UP / STANDBY**

- Upon applying power (24 volts) to 24 VAC/R, the control will reset, perform a self check routine, initiate fulltime flame sensing, flash the diagnostic LED for up to four seconds, and enter the thermostat scan state.

#### **HEAT MODE**

- When a call for heat is received from the thermostat supplying 24 volts to TH/W, the control will check the pressure switch for normally open contacts. The combustion blower is then energized and once the pressure switch contacts close, a pre-purge delay begins. Following the pre-purge period the gas valve is energized and sparks commence for the trial for ignition period.
- When flame is detected during the trial for ignition , sparks are shut off immediately and the gas valve and combustion blower remains energized. The thermostat, pressure switch, and main burner flame are constantly monitored to assure the system continues to operate properly. When the thermostat is satisfied and the demand for heat ends, the main valve is de-energized immediately, the control senses the loss of flame signal and de-energizes the combustion blower.

#### **FLAME FAILURE – RE-IGNITION**

- If the established flame signal is lost while the burner is operating, the control will respond within 0.8 seconds. The HV spark will be energized for a trial for ignition period in an attempt to re-light the burner. If the burner does not light the control will make two more attempts to re-light the burner. If the burner does not re-light, the control will go into lockout and flash the LED 3-times. If flame is re-established, normal operation resumes.

## TROUBLESHOOTING

### NO POWER TO HEATER...

**CAUTION:** Prior to performing any service or maintenance work on the unit:

- a) disconnect the electrical supply
- b) shut off gas to supply unit
- c) make sure unit has cooled down before opening service panel

#### **WARNING:**

Only allow qualified, licensed, service people trained to service gas fired heating equipment to perform any repairs on this unit. All replacement parts **MUST** originate from the manufacturer of this heater in order not to void CGA/AGA certification.

Safety devices are not allowed to be rendered inoperative and left unattended. Failure to do any of the above can cause property damage, injury or death.

### INITIAL ELECTRICAL CHECKS

- a) Make sure thermostat is calling for heat.
- b) Make sure electrical connection is secure.
- c) Check electrical supply for blown fuse or breaker.
- d) Test for power to burner head.
- e) Check wiring to components. Refer to wiring diagram on pages 62 & 63. Also refer to legend below. This legend is located on the control module.

#### **TERMINAL DESIGNATIONS**

S1	NOT USED
GND	SYSTEM GROUND (GREEN)
V2	VALVE GROUND (BROWN)
R	NOT USED
L1	120/240 VAC INPUT (HOT) (BLACK)
IND	INDUCER BLOWER OUTPUT (BLACK)
V1	VALVE POWER (WHITE)
PSW	PRESSURE SWITCH INPUT (RED)
W	THERMOSTAT INPUT (RED)

**CAUTION:** *Label all wires prior to disconnection when servicing controls. Wiring errors can cause improper and dangerous operation. A functional checkout of a replacement control is recommended.*

### INITIAL GAS CHECKS

- a) Make sure manual valve is turned on.
- b) Make sure gas valve knob is turned on.
- c) Check for gas supply and proper pressure to valve.
- d) Check wires and make sure that they and their connections are in good condition.
- e) Check for power to valve.
- f) If no power, check control board. (see page 31)

### ELECTRICITY AND GAS TO HEATER, BUT STILL IS INOPERATIVE

If after confirming that adequate gas and electricity are present and unit still does not operate, review the symptoms below. After the symptom has been identified, refer to the corresponding cause/cure. Review CHECK CONTROL BOARD section, and finalize troubleshooting procedure.

Symptom	Cause/Cure
1. Dead	A) Miswired B) Transformer bad C) Fuse/circuit breaker bad D) Bad control (check LED for steady on)
2. Thermostat on – No Blower Output	A) Miswired (check PSW terminal voltage) B) Bad thermostat – no voltage @ terminal W C) Bad control (check LED for steady on)
3. Pressure Switch, input okay but no Trial for Ignition after purge delay	A) Miswired (check PSW terminal voltage) B) Flame sense problem (existing flame-check LED-2 flashes) C) Bad control (check voltage between L1 & IND)
4. Valve on, no spark	A) Shorted electrode B) Open HV cable C) Bad control
5. Spark on, no valve	A) Valve coil open B) Open valve wire C) Bad control (check voltage between V1 & V2)
6. Flame okay during TFI, no flame sense (after TFI)	A) Bad electrode B) Bad S1 or HV wire C) Poor ground at burner D) Poor flame (check flame current)

**NOTE:** TFI = Trial For Ignition

## **CHECK CONTROL BOARD**

Open access door and view the diagnostic red LED, located on the grey direct spark ignition module.

### **FAULT CONDITIONS**

<b>Error Mode</b>	<b>LED Indication</b>
Internal Control Failure	Steady On
Air Flow Fault	1 flash
Flame with No Call for Heat	2 flashes
Ignition Lock Out	3 flashes

The LED will flash on for ¼ second, then off for ¼ second during a fault condition. The pause between fault codes is 3-seconds.

### **INTERNAL CONTROL FAULT**

- If power supply cycle are fluctuating beyond 50/60 cycles such as with an unstabilized power supply from a generator, unit will not operate. If the circuit board is faulty the unit will not operate.

### **AIRFLOW FAULT – LOCK OUT (Combustion Air Flow Problems)**

- Combustion airflow is continually monitored during an ignition sequence by the airflow switch (PSW). If during the initial call for heat the pressure switch contacts are in the closed position for 30-seconds without an output to the Combustion Blower, an airflow fault will be declared and the control will remain in this mode with the combustion blower off.
- If the airflow switch remains open for more than 30-seconds after the combustion blower output (L1 & IND) is energized, an airflow fault will be declared and the control will stay in this mode with the combustion blower off.
- If the airflow signal is lost while the burner is firing, the control will immediately de-energize the gas valve and the combustion blower will remain on. If the call for heat remains, the control will wait for proper airflow to return. If proper airflow air is not detected after 30-seconds an airflow fault signal will be declared.

Proceed as follows to verify reason for airflow lockout:

1. Check air intake and exhaust for blockage. Remove any blockage.
2. Check combustion air blower for dirt. Clean and/or replace as necessary.



- If after 1 and 2 are performed and unit still does not operate, replace air switch.

### **FLAME WITH NO CALL FOR HEAT (Flame Fault)**

- If at anytime the main valve fails to close completely and maintains a flame, the full time flame sense circuit will detect it and energize the combustion blower. Should the main valve later close off completely removing the flame signal, the combustion blower will power off.

### **IGNITION LOCK OUT (Failure to Light)**

- FENWAL DSI Module will attempt three ignition trials before going into lockout. The valve relay will be de-energized immediately, and the combustion blower will be turned off.
- Recovery from lockout requires a manual reset by either resetting the thermostat or removing 24 volts, or removing the electrical power supply for a period of 5-seconds.
- If the thermostat is still calling for heat after one hour, the control will automatically reset and attempt to ignite the burner again.

If units still does not operate, proceed as follows:

- Check flame sensor current. (see below)
- Check electrode for cracks and proper location. (see page 33)

### **FLAME SENSOR CURRENT CHECK**

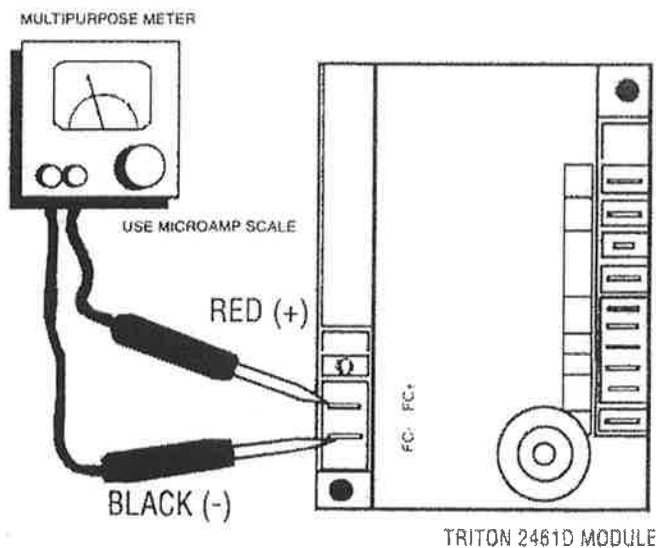

### **SERVICE CHECKS**

Flame current is the current which passes through the flame from the sensor to the ground. The minimum flame current necessary to keep the system from lockout is .7 microamps. To measure flame current, connect an analog DC microammeter to the FC- FC+ terminals per figure. Meter should read .7 uA or higher. If meter reads below "0" on scale, meter leads are reversed. Disconnect power and reconnect meter leads for proper polarity.

Figure #21– Flame Sensor Current Check

## **PROPER ELECTRODE LOCATION**

Proper location of the electrode assembly is important for optimum system performance. The electrode assembly should be located so that the tips are inside the flame envelope about  $\frac{3}{4}$  to 1 inch.

### **CAUTIONS**

1. Ceramic insulators should not be in or close to the flame
2. Electrode assemblies should not be adjusted or disassembled. Electrodes should have a gap spacing of .125" (3.175mm). If this spacing is not correct, the assembly must be replaced. Electrodes are NOT field adjustable.
3. Exceeding the temperature limits can cause nuisance lockouts and premature electrode failure.

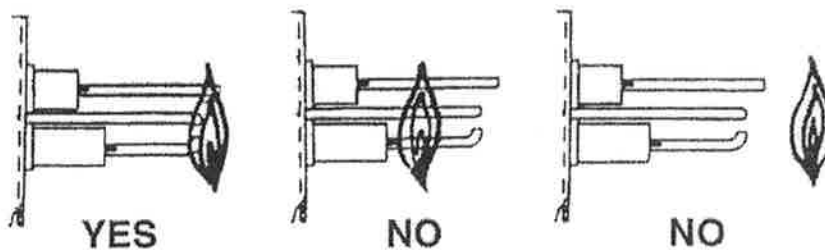

Figure #22 – Proper Electrode Location

## **MAINTENANCE**

Maintenance is required once a year. Annually inspect your heater, before the heating season starts. If unit is in a dusty environment, maintenance will be required more often. If dust conditions are extreme, monthly or weekly maintenance may be required.



### **WARNING**



Disconnect electrical supply to heater and shut off gas prior to inspection.

- A) Check combustion air intake for blockage.
- B) Check exhaust terminal for blockage.
- C) Open service door.
- D) Check blower motor and scroll for dirt and/or locked rotor. Remove dirt with compressed air or vacuum cleaner. If rotor is locked, replace assembly.
- E) If burner needs cleaning, remove burner head from tube and use a combination of compressed air and/or a wire brush to remove any deposits or debris that may be on the actual burner.
- F) Make sure all wiring is intact and in good condition.
- G) Check electrode for proper gap and cleanliness. Clean or replace as necessary.
- H) Check ignition system for spark. Replace as necessary.
- I) Check exchanger tube for holes and/or cracks, dirt and/or deposits. Clean and/or replace as necessary.
- J) Wash any dirt or dust off of the unit with a soap and water solution.
- K) Check any gas connections that were disconnected during maintenance for leaks. Use soap and water solution. **DO NOT USE FLAME.**
- L) Test fire unit by turning control "on". Make sure unit is operating quietly and efficiently.
- M) Periodically visually check burner through view port to confirm proper operation.
- N) Check all couplers for tightness and/or leakage.



### **WARNING**



Only allow qualified/licensed service people, trained to service gas fired heating equipment, to perform any repairs on this unit. All replacement parts **MUST** originate from the manufacturer of this heater in order not to void CGA/AGA certification. Safety devices are not allowed to be rendered inoperative.



### **WARNING**



Improper installation, adjustment, alteration, service or maintenance can cause property damage, injury or death. Read the installation, operating and maintenance instructions thoroughly before installing or servicing this equipment.

The heater area must be kept clear and free from combustible materials, gasoline and other flammable vapors and liquids.

The flow of combustion and ventilation air to heater must not be obstructed.

# BURNER HEAD & RELATED PARTS

(Refer to page 37 for part numbers & description)

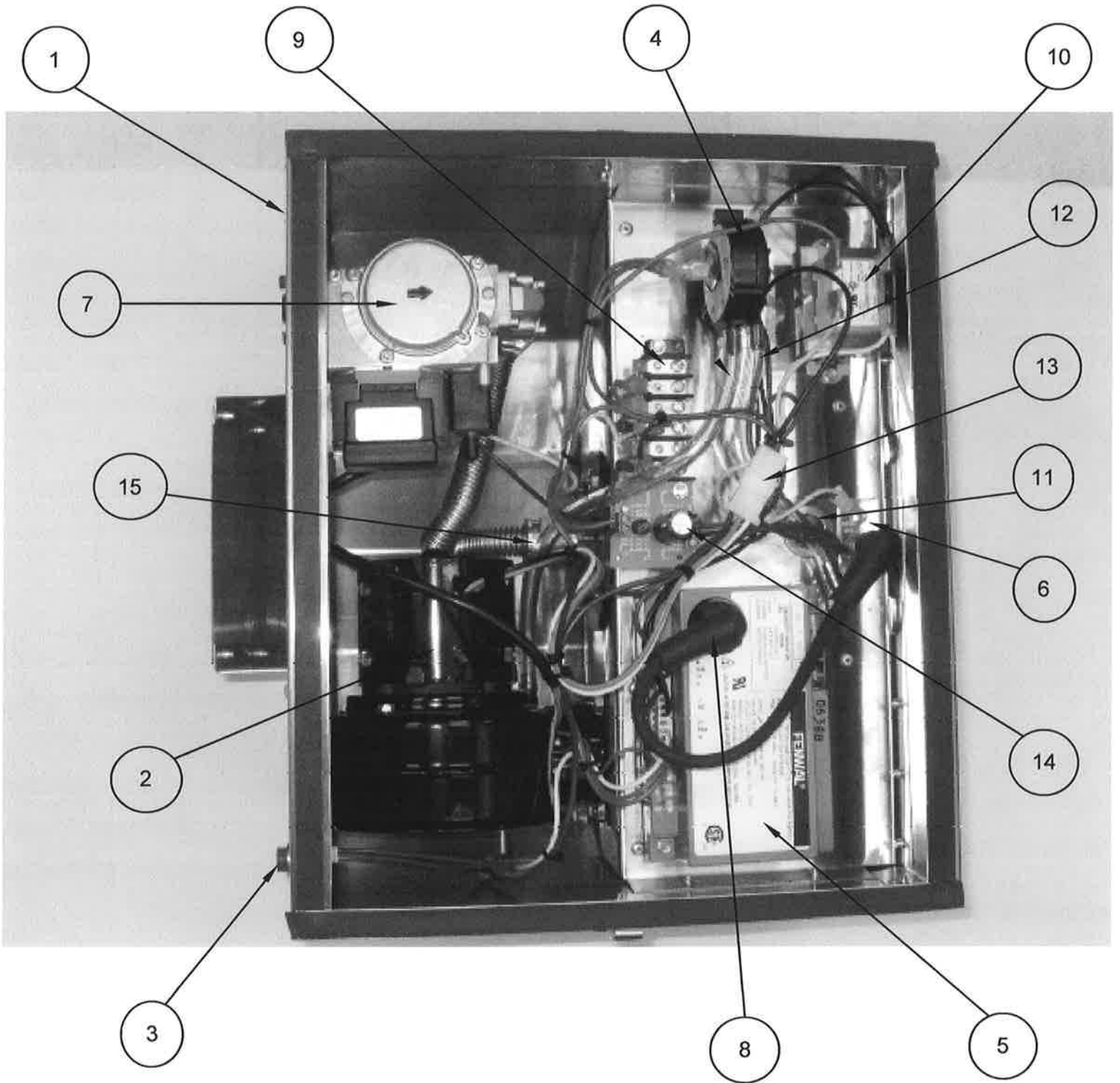

FIGURE #23 BURNER HEAD PARTS

# REFLECTOR AND TUBE PARTS

(Refer to page to page 37 for part numbers and descriptions)

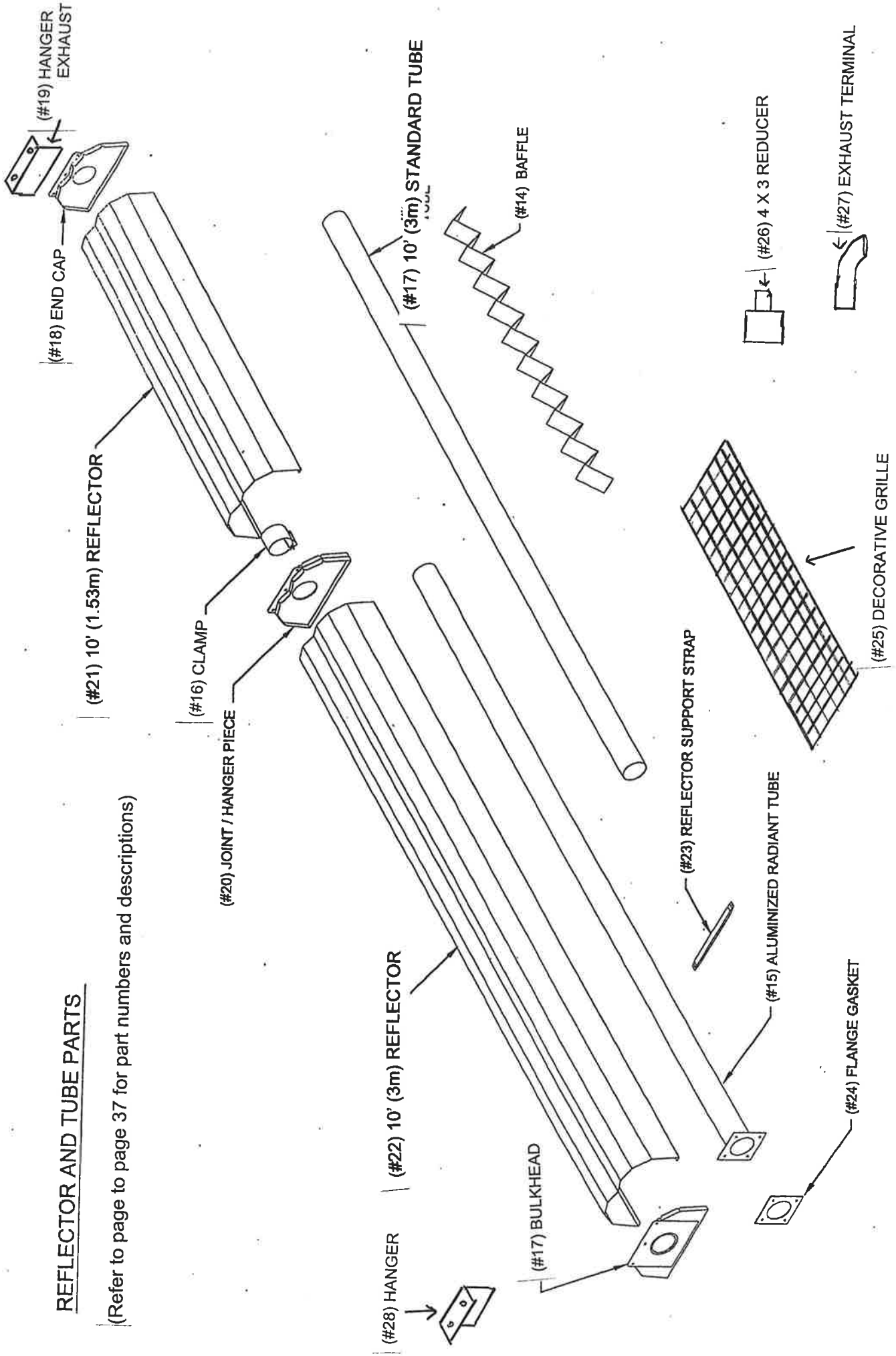

FIGURE #23 REFLECTOR AND TUBE PARTS

See page 35 &amp; 36 for visual detail

**REPLACEMENT BURNER HEADS**

ITEM #	PIN	INPUT	FUEL	WEIGHT
1	5120000	PH - 40	NG	32 lbs (36 kg)
1	5120001	PH - 40	LP	32 lbs (36 kg)
1	5120002	PH - 50	NG	32 lbs (36 kg)
1	5120003	PH - 50	LP	32 lbs (36 kg)
1	5120004	PH - 75	NG	32 lbs (36 kg)
1	5120005	PH - 75	LP	32 lbs (36 kg)

**BURNER HEAD COMPONENTS**

ITEM #	PIN	DESCRIPTION	WEIGHT (lbs)
2	3010001	Blower Motor Assembly	**
3	1090C1	Indicator Light	**
4	3070401	Air Switch PH - 40	**
4	3070402	Air Switch PH - 50	**
4	3704003	Air Switch PH - 75	**
5	3030021	Direct Spark Ignition Module ( Fenwal)	**
6	3030633	Electrode Assembly	**
7	3020005	Gas Valve LP	**
7	3020003	Gas Valve NG	**
8	3030026	High Voltage Ignition Wire	**
9	3070025	Terminal Block	**
10	3070016	Transformer	**
11	3110022	View Port - Mica Window	**
12	5040374	Vinyl Hose for Differential Air Proving Switch	**
13	3070321	Wire Harness	**
14	LX1000	Variable Input Control	**
15	590156	Burner Assembly	**

**TUBE COMPONENTS**

ITEM #	PIN	DESCRIPTION	WEIGHT (lbs)
16	5170147	Baffle Turbulator	5 lbs (2.3 kg)
17	3170325	Flanged Tube Aluminized PH - 40	30 lbs (13.7 kg)
17	3170327	Flanged Tube Aluminized PH - 50 & 75	30 lbs (13.7 kg)
18	37760	Radiant PH - 75	15 lbs (6.8 kg)
19	37759	Radiant PH - 50	30 lbs (13.7 kg)
20	3170201	Tube Clamp	**
21	715013	PH-40 High Output Tube Assembly	45 lbs (21 kg)
22	715014	PH-75 High Output Tube Assembly	65 lbs (30 kg)
23	3200744	4 x 3 Reducer	5 lbs (2.3 kg)

**REFLECTOR COMPONENTS**

ITEM #	PIN	DESCRIPTION	WEIGHT (lbs)
24	5120034	PH Bulkhead SS	5 lbs (2.3 kg)
25	5120033	PH End Cap SS Exhaust	5 lbs (2.3 kg)
26	5120040	PH - 50 & 75 Hanger Assembly	5 lbs (2.3 kg)
27	5180161	Reflector 5' (1.53m)	10 lbs (4.54 kg)
28	5180162	Reflector 10' (3m)	20 lbs (9.1 kg)
29	5180708	SS Reflector SupportStrap	**
30	5080319	Flange Gasket	**
31	4160152	Decorative Egg Crate Grill	5 lbs (2.3 kg)
32	715001	PH-40 High Output Reflector Assembly	15 lbs (6.8 kg)
33	715007	PH-75 High Output Reflector Assembly	30 lbs (13.7 kg)

Calcana USA Ltd. ("the Manufacturer") warrants to the original owner at the original installation site that the heater manufactured by the manufacturer ("the Product") will be free from defects in material and workmanship for one (1) year from date of shipment from the factory. Calcana further warrants that the heat exchanger, reflectors, brackets, burner and burner box will be free from defects in material and workmanship for three (3) years from the date of shipment from the factory. If upon examination by the Manufacturer the Product is shown to have a defect in the material or workmanship during the warranty period, the Manufacturer will repair or replace, at its option, that part of the Product which is shown to be defective. In no event shall the customer be entitled to consequential, indirect or special damages of any nature for defective merchandise, and in no instance may damages include loss of profit. Calcana reserves the right to inspect the system involved in any claim against the warranty. The warranty is null and void if any of the components installed are not original Calcana parts, or the installation does not conform to the supplied installation manual.

This limited warranty does not apply;

- a) if the Product has been subjected to misuse or neglect, has been accidentally or intentionally damaged, has not been installed, maintained or operated in accordance with the furnished written instructions, or has been altered or modified in any way by an unauthorized person.
- b) To any expenses, including labour or material, incurred during removal or reinstallations of the Product.
- c) To any damage due to corrosion by chemicals, including halogenated hydrocarbons precipitated in the air.
- d) To any workmanship of the Installer of the Product
- e) If Product is not paid for in a timely manner and in accordance with payment terms
- f) If Product or any part of it is damaged by any act of nature including, but not limited to; hurricanes, gales, tornadoes, wind snow, sleet, hail, rain, flood, fire or any other similar or dissimilar condition, or by normal wear and tear, which included marks and/or dents to the reflector caused by improper transportation or installation.
- g) If Product or any part of it is damaged by vandalism, improper use, accumulation of weight or heavy loads on the heater.

- h) If Product is damaged due to lack of cleaning or maintenance, whether routine or otherwise.

The limited warranty is conditional upon;

- a) Advising the installing contractor, who will in turn notify the distributor or Manufacturer
- b) Shipment to the Manufacturer of that part of the Product thought to be defective. Goods can only be returned with prior written approval of the Manufacturer. All returns must be freight prepaid.
- c) Determination in the reasonable opinion of the Manufacturer that there exists a defect in material or workmanship.

Repair or replacement of any part under the Limited Warranty shall not extend the duration of the warranty with respect to such repaired or replaced part beyond the stated warranty period.

This Limited Warranty is in lieu of all other warranties, either express or implied, and all such other warranties, including without limitation implied warranties of merchantability and fitness for a particular purpose, are hereby disclaimed and excluded from this limited warranty. The warranty cannot be transferred or assigned by the Customer. All disputes arising from this warranty are to be governed by the laws of the State of Alabama and any action to enforce this warranty must be initiated in the State of Alabama. In no event shall the Manufacturer be liable in any way for any consequential, special, or incidental damages of any nature whatsoever, or for any amounts in excess of the selling price of the Product or any parts thereof found to be defective. This Limited Warranty gives the original owner of the Product specific legal rights. You may also have other rights which may vary by each jurisdiction.

USA  
Calcana USA Ltd.  
30345 Suite A,  
County Rd 49  
Loxley, AL, 36551  
Tel: 251-964-4400  
Fax: 251-964-4404

## Models CAL AND PH Series Heaters.

The conversion shall be carried out in accordance with the requirements of the provincial/state authorities having jurisdiction and in accordance with the requirements as follows:

**CANADA:** *Natural Gas and Propane Installation Code, CSA B149.1* or latest edition.

**USA:** *National Fuel Gas Code, ANSI Z223.1/NFPA 54*, or latest edition.

**⚠ WARNING:** This conversion kit shall be installed by a qualified service agency in accordance with the manufacturer's instructions and all applicable codes and requirements of the authority having jurisdiction. If the information in these instructions is not followed exactly, a fire, explosion or production of carbon monoxide may result causing property damage, personal injury or loss of life. The qualified service agency is responsible for the proper installation of this kit. The installation is not proper and complete until the operation of the converted appliance is checked as specified in the manufacturer's instructions supplied with the kit. The installer of this conversion kit assumes full responsibility and liability for the installation of this conversion kit. If you do not understand these instructions or the information contained in the installation manual, **DO NOT INSTALL THIS CONVERSION KIT OR OPERATE THE UNIT ASSOCIATED WITH THIS GAS CONVERSION.**

**DIRECTIONS:**

- 1) Caution the gas supply shall be shut off prior to disconnecting the electrical power, before proceeding with the conversion.
- 2) Turn off electrical supply to heater
- 3) Disconnect gas supply line to heater
- 4) Disconnect electrical supply to heater
- 5) Disconnect thermostat/control wire from heater
- 6) Remove burner head from reflector assembly being careful to support burner head in such a fashion that it will not fall from the location overhead where it was installed. Use two people if necessary.
- 7) Remove service door that provides access to gas valve location
- 8) Remove ignitor assembly
- 9) Use deep wall socket to remove orifice spud.
- 10) Install correct orifice for the fuel that you are converting to. **CHECK TWICE TO MAKE SURE.** Reference chart below:
- 11) Locate gas valve and **REPLACE WITH THE GAS VALVE IN CONVERSION KIT.** Verify you have the correct valve for the fuel type you want to convert to. **CHECK TWICE TO MAKE SURE.**
- 12) **Verify Manifold pressure using a manometer. Adjust pressure if necessary. (see valve instructions for details)**  
**Manifold Pressure is: NG: Hi 3.5 "w.c" Lo 1.5" w.c.**  
**LPG: Hi 10.5" w.c. Lo 5.5" w.c.**

**Leak Test all Fittings Prior to Operation**

- 13) When the conversion is complete, fill out the information as required on the enclosed conversion label.
- 14) **Attach completed label on or near the rating plate**

**Conversion Chart With Part Numbers and Corresponding Orifice Sizes**

MODEL	PIN	FROM	TO	ORIFICE
CAL/PH 40	3025025	NG	LPG	#51
CAL/PH 50	3025026	NG	LPG	#48
CAL/PH 75	3025027	NG	LPG	#42

MODEL	PIN	FROM	TO	ORIFICE
CAL/PH 40	3025028	LP	NG	#32
CAL/PH 50	3025029	LP	NG	3.3mm
CAL/PH 75	3025030	LP	NG	#21

NOTE: CONVERSION KITS COME WITH GAS VALVE, PREDRILLED ORIFICE AND CONVERSION LABEL.  
 CONVERSION KITS ARE FOR UNITS RATED FOR THE FOLLOWING LOCATIONS AND ELEVATIONS:  
 FOR INSTALLATIONS ABOVE THE DESIGNATED ELEVATIONS, CONTACT FACTORY.

CANADA: 0 – 4500 FT (1372 m)  
 USA: 0 – 2000 FT (610 m)



**Calcana USA Ltd.**  
 30245 Suite A  
 County Rd 49  
 Loxley, AL, 36551,  
 Tel: 251-964-4400





## VALVE DETAILS

- |  |  |
|--|--|
| <ol style="list-style-type: none"> <li>1 Solenoids V1 + V2</li> <li>2 Electrical connection V1/V2 Molex Serie 3000</li> <li>3 Servo governor</li> <li>4 Main gas outlet</li> <li>5 Test nipple p<sub>1</sub></li> <li>6 Main gas Inlet p<sub>1</sub></li> <li>7 Ignition gas outlet</li> <li>8 Test nipple p<sub>2</sub></li> <li>9 Setting screw for governor with SW 2 socket head</li> <li>10 Setting screw for start gas volume or slotted screwdriver</li> <li>11 <b>only GB-GD...D01 and GB-N... D01</b><br/>Signal p<sub>stat</sub> connection</li> <li>12 <b>only GB-GD...D01 and GB-N... D01</b><br/>"Min" setting screw K (SW 2) 0-point offset</li> </ol> | <ol style="list-style-type: none"> <li>13 <b>only GB-GD...D01 and GB-N... D01</b><br/>"Max" setting screw V (SW 2) Ratio adjustment</li> <li>14 <b>GB-M... D01 only</b><br/>Cover</li> <li>15 <b>GB-M... D01 only</b><br/>setting screw SW 3 Min</li> <li>16 <b>GB-M... D01 only</b><br/>setting screw SW 2 Max</li> <li>17 <b>GB-M... D01 only</b><br/>Modulator</li> <li>18 <b>GB-M... D01 only</b><br/>Modular power supply, Male connector AMP 6,3 x 0,8 mm</li> <li>19 Solenoid retaining screw</li> <li>20 Side cover with screws</li> </ol> |
|--|--|

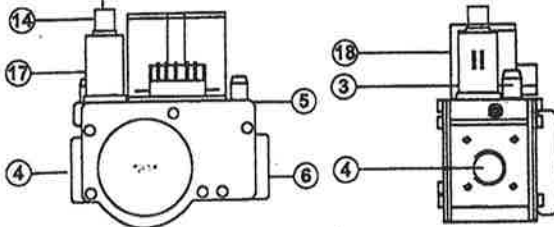
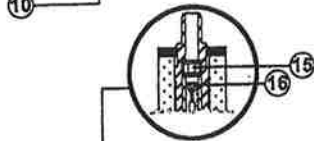
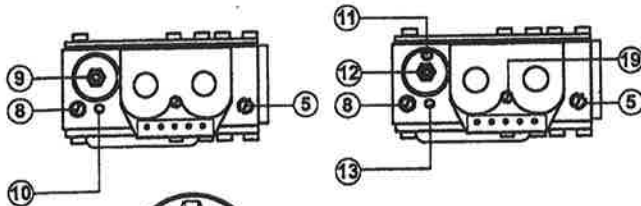
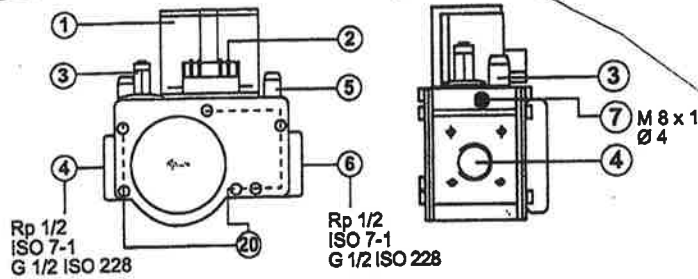

## SETTING MANIFOLD PRESSURE

### Setting the modulator

**⚠ Caution!**  
Always set Min first since Max is adjusted simultaneously!

### Setting Min

A Remove electrical connection 18 from modulator

**⚠ Caution!**  
Do not use ball head tools with a 3 mm shaft. Otherwise Min is adjusted simultaneously!

B Set small load, setting screw 15 (use 3 mm socket head):

higher pressure  
counterclockwise

lower pressure  
clockwise

### Setting Max

Operate Heater On HIGH

C Set Max, setting screw 16 (2 mm socket head)

60° corresponds to approx. 1 mbar

higher pressure  
counterclockwise

lower pressure  
clockwise

On completion of work on the GB-M... D01, perform a leakage and function test.

REFER TO RATING PLATE FOR MIN/MAX MANIFOLD PRESSURES

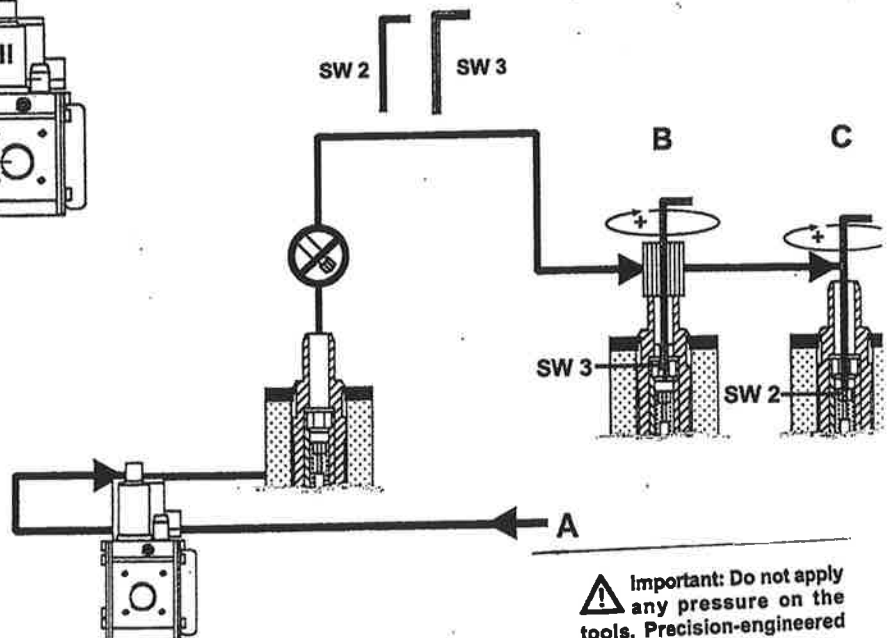

**⚠ Important:** Do not apply any pressure on the tools. Precision-engineered tools.

**EXAMPLE OF CONVERSION KIT LABEL  
TO BE COMPLETED AS PER INSTRUCTIONS IN KIT**

This appliance was converted on DAY: \_\_\_\_\_  
 MONTH: \_\_\_\_\_ YEAR: \_\_\_\_\_  
 to NG: \_\_\_\_\_ LP. \_\_\_\_\_ gas with Kit # \_\_\_\_\_  
 by: NAME: \_\_\_\_\_  
 COMPANY: \_\_\_\_\_  
 ADDRESS: \_\_\_\_\_  
 CITY/TOWN: \_\_\_\_\_ STATE/PRO: \_\_\_\_\_  
 TELEPHONE: \_\_\_\_\_  
 Orifice Size: \_\_\_\_\_ Leak Test Performed: Yes: \_\_\_\_\_  
 Manifold Pressure: Min \_\_\_\_\_ Max \_\_\_\_\_  
 Input: \_\_\_\_\_ Altitude: \_\_\_\_\_  
 (The name of the individual and organization making  
 this conversion accepts the responsibility that this conversion  
 has been properly made and has performed a leak test on the  
 appliance prior to placing into service.) Locate label in a  
 conspicuous location on the appliance near rating plate.  
 =====  
 Cet appareil a ete converti au: \_\_\_\_\_  
 Injecteur: \_\_\_\_\_ Date: \_\_\_\_\_  
 Pression a la tubulure d'alimentation: \_\_\_\_\_  
 Debit calorifique: \_\_\_\_\_

## WARNING

Fire or Explosion Hazard

**Failure to follow these instructions will cause death, personal injury or property damage. Read the installation, operating and maintenance instructions thoroughly before installing or servicing this equipment.**

### **SAFETY INSTRUCTIONS READ BEFORE OPERATING**

- A.** This heater does not have a pilot. It is equipped with an ignition device which automatically lights the burner. **DO NOT** try to light the burner with a match.
- B. BEFORE OPERATING**, smell all around the heater area for gas. Be sure to smell next to the floor because some gas is heavier than air and will settle to the floor.

### **WHAT TO DO IF YOU SMELL GAS**

- Do not try to operate heater.
- Do not touch any electric switch; do not use any phone in your building.
- Immediately call your gas supplier from a neighbor's phone. Follow the gas supplier's instructions.
- If you cannot reach your gas supplier, call the fire department.
- C.** Use only your hand to turn the gas valve handle. Never use tools. If the handle will not turn by hand, do not try to repair it, call a qualified service technician. Force or attempted repair may result in a fire or explosion.
- D.** Do not use this heater if any part had been under water. Immediately call a qualified service technician to inspect the heater and to replace any part of the control system which has been under water.

### **OPERATING INSTRUCTIONS**

1. **STOP!** Read the safety instructions on this label.
2. Open the manual gas valve in the heater supply line.
3. Turn on electric power to the heater.
4. Set the thermostat or control to the desired setting.
5. This heater is equipped with an ignition device, which automatically lights the burner. Do not try to light the burner with a match.
6. If the heater will not operate, follow the instructions "To Turn Off Gas To Heater" and call your service technician or gas supplier.

### **TO TURN OFF THE GAS TO HEATER**

1. Set the thermostat or control to the lowest setting.
2. Turn off electric power to the heater if service is to be performed.
3. Turn off the manual gas valve in the heater supply line.
4. Wait 5 minutes before attempting to relight heater.